



AY2022
Kyushu University
Graduate School of Design
Student Handbook

(The name of each course is as follows.)

In this booklet, the following abbreviations are used for each course name.

Strategic Design Course: SD

Environmental Design Course: Environment

Human Life Design and Science Course: Human Life, Human, HLD

Design Futures Course: Design Futures, Future

Media Design Course: Media, MD

Acoustic Design Course: Acoustic

<Cover> Student Works

Yuki Tokuyama, Department of Visual Communication Design

Preface

Kyushu University Graduate School of Design Dean

Kyushu University School of Design Dean

OMOTO Akira



Welcome to the World of Design

The Kyushu University School of Design and the Graduate School of Design were established initially in 1968 to train "world-class designers" to achieve the "humanization of technology." The school was merged with Kyushu University in 2003 and has undergone several reorganizations to reach its current form.

The purpose and nature of the School of Design, as compiled by the University Establishment Council when the Kyushu Institute of Design was established in 1968, are as follows:

1. In order to make appropriate use of general technology in life, there is a need to integrate science, which is the basis of technology, and art, which is the freest expression of the human spirit, and to plan the course of technology and study the design of its functions based on the overall spirit of these two fields.

2. The organization of modern society has become more complex. As a result, the scope of work that university graduates will be involved in has expanded. Also, there is a growing demand for designers with the knowledge and artistic sensibilities that span the humanities, social sciences, and natural sciences, in addition to traditional designers. As such, we need to respond to this demand.

At the same time, the technology was probably associated with heavy industry. As time changes, it is associated with the current information and communication technology. Even though design has taken a broader meaning, and graduation from graduate schools has become common, our purpose does not become obsolete with time.

It will soon be 20 years since we merged with Kyushu University. These objectives and the philosophy of "humanization of technology" remain essential as the only School of Design and Graduate School of Design in the comprehensive university.

At the same time, we need to be sensitive to the changes in the social environment surrounding us. In order to appropriately respond to the ever-changing design subjects and methodologies of the times, we have reorganized the School of Design in 2020 and the Graduate School of Design in 2022. The five new courses in the School of Design and the six courses in the Graduate School of Design created as a result of this reorganization are the expression of our convinced will to actively expand the scope of design from "mono" to "koto" and into the realm of envisioning the future while preserving the good traditions of the past.

With the reorganization, the curriculum has also been renewed with a strong emphasis on a broad range of "fusion." It is a fusion of different design subjects and even different methodologies. To achieve this, we have established a credit system

that allows students to study in other fields and more project-based subjects than ever before.

Students are free to design their course of study within a defined scope at university. At first glance, fusion with other fields tends to be seen as a "broad and shallow" learning system. However, depending on the approach, students can make this a "broad and deep" learning experience.

This handbook provides the subjects and various structures for education and research in designing pathways to solutions for various problems in culture, art, science, engineering, and society. It serves as a guideline and agreement for both students and faculty members who teach these subjects, thus leading students to become world-class designers.

We hope that you will make active use of this handbook and the various resources available at Kyushu University and Ohashi Campus to have an enriching educational experience

Table of Contents

Preface

Chapter 1: Curricula and Courses of the Graduate School of Design

1. Philosophy and Objectives	1
2. Educational Philosophy and Goals of the Master's Program in the Department of Design	2
(1) Strategic Design Course	2
(2) Environmental Design Course	2
(3) Human Life Design and Science Course	3
(4) Design Futures Course	3
(5) Media Design Course	4
(6) Acoustic Design Course	4
3. Requirements for Completion of the Master's Program in the Department of Design	6
A. Completion Requirement	6
B. Detailed Course Descriptions	7
(1) Master's Program (Strategic Design Course)	7
(2) Master's Program (Environmental Design Course)	10
(3) Master's Program (Human Life Design and Science Course)	14
(4) Master's Program (Design Futures Course)	17
(5) Master's Program (Media Design Course)	20
(6) Master's Program (Acoustic Design Course)	23
4. Requirements for Completion of the Doctoral Program in the Department of Design	26
A. Completion Requirements	26
B. Doctoral Course Detailed Description	26
5. About Taking the Subjects	27
(1) Timetable	27
(2) Academic Schedule	27
(3) Subject Registration	27
(4) Notes on Subject Registration	28
(5) Cancellation of Classes Due to Natural Disasters	28
(6) Absence from Classes and Examinations	28
(7) Syllabus	29

(8) Examination	29
(9) Notes on Regular Examinations	30
(10) Confirmation of Grades and Credits Earned	31
(11) Period for Confirmation of Grades	31
(12) Internship	31
(13) Kikan Education Subjects in Graduate School	32
(14) Extension of the Period of Study	32
6. Submission of Thesis	33
7. Professional Certificate Programs	36
(1) Cultural Hall Management Engineer Training Program	36
(2) Global Architect Program	38
(3) Creative Leadership Program	40
8. Qualification	43
9. Doctoral Research Progress Report	44
10. JSPS Research Fellowship for Young Scientists	44

Chapter 2 Student Life at Ohashi Campus

1. Departments Relevant to Students	47
2. Academic Procedures	48
(1) Standard Period of Study and Limitation Period	48
(2) Leave of Absence, Resume Studies, and Withdrawal	48
(3) Procedures for Changing Your Current Address, Phone Number, E-mail Address, Domicile, Guarantor or Guarantor's Address, Family Name, and Residence Card	49
(4) Payment of Tuition Fees	49
(5) Other Procedures	50
3. Dissemination of Information for Students at Ohashi Campus	51
(1) Dissemination of Information	51
(2) Handling of Mail	52
(3) Telephone Service	52
4. Issuance of Certificates	52
(1) Student ID Card	52
(2) Commuter Pass	53
(3) Issuance of Certificates at the Automatic Machines.....	53
5. Consultation on Student Life, Study, and Employment Guidance	54
(1) Academic Consultation	54

(2) Consultation Services	54
(3) Office Hour System	54
(4) Harassment Consultation.....	54
(5) Study Abroad	55
(6) Geiko Student Supporters	57
6. Others	57
(1) Regular Health Checkups for Students	57
(2) Employment Support	57
(3) Traffic Regulations on Campus	58
(4) Notes on Student Life	59
7. How to Conduct Proper Research	59
8. Club Activities	60
9. Use of Ohashi Campus Facilities	60
10. Safety Guide	68
11. Reporting of Award Information	73

Appendix

1. Building Layout Map of the Campus	75
2. Floor Plan of Each Building and Facility	76
3. Kyushu Institute of Design School Song	100

Chapter 1

Curricula and Courses of the Graduate School of Design

1. Philosophy and Objectives

Based on the purpose of education and the four principles (principle of humanity, principle of sociality, principle of internationality, and principle of professionalism) stipulated in the Kyushu University Educational Charter, the image of the human resources to be cultivated in the Graduate School is that of world-class designers who will inherit the philosophy of "humanization of technology" that fuses science and technology with the artistic sensibility to face the challenges facing humankind sincerely, and who will base on an awareness of the new design field that expands from "mono" to "koto" to "visions" and broad knowledge of humanities, society, and nature.

[Master's Program]

For the educational philosophy of the master's program in the Department of Design, please refer to the page of each course (P.2-5).

The master's degree in the Department of Design is awarded to those who have achieved their goals and acquired the ability to play a leading role in the real world while fully understanding the basics and foundation of design through the educational subjects offered in each course of the master's program.

In addition, a master's degree in design strategy is awarded to those who have acquired expertise in entrepreneurship and design practice, which are the characteristics of the Strategic Design Course, and who have engaged in master's research related to design and business.

[Doctoral Program]

In today's increasingly complex society, there is a need for experts who have a deep understanding of culture and can promote the correct evaluation of objects and the creation of "mono," "koto," and "visions" compatible with human needs. The doctoral course in the Department of Design aims to train human resources who can create human-compatible environments and products, improve the quality of various types of information, and create art and culture based on the viewpoint of design studies without being limited to a specific field. Within the fields of design, the program sets up areas for each student to acquire advanced and cutting-edge knowledge of art, science, and technology and provides them with opportunities to conduct basic and applied research, content creation, and practice based on this knowledge.

In the doctoral program of the Department of Design, the doctoral degree of "Doctor of Philosophy in Design" is awarded to those who have achieved results by acquiring sufficient specialized knowledge and particularly outstanding technology in design and who have produced original research results of an international standard in which they have set and solved new problems. In addition, the doctoral degree of "Doctor of Engineering" is awarded to those who, in the opinion of the faculty advisor group, have achieved satisfactory results from an engineering standpoint in their research on design, particularly in technology.

2. Educational Philosophy and Goals of the Master's Program in the Department of Design

(1) Strategic Design Course

Based on the educational philosophy of "higher-order design," this course primarily cultivates the following abilities to develop the ability to accurately judge, create, propose, and execute various relationships and directions that strategically promote design in the process of the design business.

- Tackle issues in a wide range of fields practically while finding problems on one's own and examining them creatively and critically, backed by deep expertise in society, the economy, industry, the environment, and human beings.
- High level of expertise in design practice from conceptualization, actual planning, production, intellectual property, distribution, and sales, as well as a high level of expertise in entrepreneurship such as leadership and team communication, and the ability to explain the methodology based on a thorough understanding of these areas.
- Higher-order design ability to construct methodologies for entrepreneurship and practice based on business knowledge and entrepreneurship, including the ability to utilize intellectual property from business fundamentals, and methodologies to develop new design needs concerning society, the economy, and industry and link them to solutions.
- Raise complex social issues and provide practical directions for solutions through collaboration with disciplines different from design while comprehensively utilizing specialized knowledge.
- Grasp, envision, and implement strategies related to the social implementation of design and business, evaluate, and analyze them, and construct methodologies that lead to entrepreneurship and social practice.

The program will also develop "human resources who can accurately grasp, envision and implement various relationships and directions related to design strategies," "human resources who can evaluate and analyze these relationships and directions," and "human resources who have acquired the expertise to lead innovation and who can construct methodologies for starting and practicing businesses based on business knowledge and entrepreneurship."

(2) Environmental Design Course

Based on the environmental design philosophy of the coexistence of humans and the environment, this course aims to create future regions and living environments by learning from the sustainability and diversity of nature and culture, the values of the environment that humans have inherited from the past, and will hand down to the future. In addition, the course aims to develop human resources to be leaders with the following comprehensive research and design skills to be responsible for designing a better environment for the future in a wide range of occupations, such as

researchers in universities, research institutes, and museums; administrators in architecture, landscaping, urban planning, cultural promotion, and environmental policy; planners in town and village development; managers in heritage protection and restoration; designers in architecture, landscaping, and landscape architecture; and engineers in architecture, landscaping, and other fields.

- 1) Through practical education in domestic and international fields, evaluate the value of various environments and support the international network of environmental design.
- 2) Acquire expertise in designing sustainable architecture, landscapes, and social systems to assess the value of the environment and pass it on to the future and contribute to the maintenance and improvement of the environment.
- 3) Learn about the process of realizing safety, health, functionality, and comfort that enables sustainable design based on the relationship between humans and the environment and will be able to support environmental design from a technical perspective with spatial harmony and a temporal perspective.

In addition, the Global Architect Program is offered as part of the JABEE bachelor's and master's degree program in architecture (Environmental Design Program) that corresponds to the international architectural qualifications, fosters human resources with comprehensive design skills, engineering knowledge of architecture, and environmental design, and knowledge of culture and art.

(3) Human Life Design and Science Course

The course aims to develop human resources to understand and conceptualize the way of life from a bird's eye view based on human characteristics and advanced science and technology and to be able to apply this knowledge to realize the ideal way of life. Specifically, it aims to develop human resources who understand the physiological, morphological, behavioral, and psychological characteristics of humans, who rethink the way of life based on human sensitivity and creativity, and who can apply and integrate knowledge to create a scientifically and culturally richer life, and who have the cutting-edge scientific knowledge to realize a safe, secure, and enriching life. The graduates are expected to be active as researchers, designers, creative directors, planners, analysts, consultants, facilitators, design engineers, designers, and developers who analyze, conceive and practice human life and society in a wide range of fields such as information equipment, home appliances, automobiles, furniture, household goods, space, architecture, urban planning, trading companies, advertising agencies, application, and system development, printing companies, publishing companies, information architects, experience design, banks, government agencies, universities and other educational and research institutions. We aim to provide education that contributes to this goal.

(4) Design Futures Course

The course aims to acquire knowledge and methodologies in the fields of information science, life science, design art, and design culture, and conduct

education and research to develop a vision of the future society with a multifaceted and creative approach and realize it.

It aims to develop the ability to systematically understand and explain the knowledge of information science and life science to utilize it in constructing and creating a future society.

It aims at developing the ability to systematically understand, explain, and practice art production, theories of expression, management, and techniques that bridge art, design, society, and culture.

It aims to develop the ability to systematically understand and explain creative and cutting-edge techniques related to philosophy, environmental studies, sociology, pedagogy, and art that support the life sciences and the global environment.

Furthermore, based on a comprehensive understanding of design and future design, students will be able to make full use of the acquired knowledge and methodologies of information science, life science, design and art, and design culture to contribute to the presentation of scientific knowledge, the solution of social problems, and the creation of culture.

The graduates are expected to be active in a wide range of fields, including creators and design consultants involved in the creation of services, experiences, and systems; planners in charge of creating new lifestyle values and product values; UX designers who design services for manufacturers; researchers and planners who conduct research and analysis at manufacturers' design centers; data scientists who analyze social data and life information at research institutes; administration positions involved in the design of national and local policies; international management professionals; and researchers through graduate study. We aim to provide education that contributes to these fields.

(5) Media Design Course

The course aims to nurture human resources who will take up challenges and pioneer a new era of media design, including advanced creators and researchers with an international perspective, applying leading media technology, and creating artistic culture through the cultivation of logical thinking skills and aesthetic sensibilities.

To this end, the course offers comprehensive studies in media design through various activities in the four fields of design science, design engineering, media expression, and media socio-cultural studies.

The graduates are expected to be active in many fields as creators, planners, engineers, educators, and researchers in the fields of content design, information design, and media communication.

(6) Acoustics Design Course

This course aims to nurture human resources who can create human-compatible sound environments, improve the quality of acoustic information, and create sound-related art and culture based on the perspective of sound-related design.

To this end, students acquire advanced and cutting-edge knowledge of art, science, and technology related to acoustic design and receive a practical education that

includes basic and applied research and production of artworks based on this knowledge.

This course is designed to nurture human resources capable of designing total communication of audiovisual information based on advanced and cutting-edge knowledge of art, science, and technology related to sound and well-versed in the environment's characteristics. In other words, students will have the sensitivity to sound and advanced specialized knowledge necessary for acoustic design specialists, the ability to fully understand and explain concepts, ideas, and methodologies, and the ability to use sound-related art, science, and technology knowledge to solve problems. The program aims to help students acquire the ability to plan and carry out research that contributes to creating human-friendly sound environments, enhancing the quality of acoustic information, and creating sound-related art and culture.

Graduates are expected to be active in a wide range of fields such as information processing, video communications, broadcasting, broadcasting equipment, musical instrument manufacturing, automobile industry, medical technology, medical equipment industry, architectural acoustics, noise control, sound environment planning, vocal language education, production, entertainment industry, start-ups, music management, theater and hall management, government research institutes, and university education and research. We aim to provide education that contributes to these areas.

3. Requirements for Completion of the Master's Program in the Department of Design

A. Completion Requirement

Students must be enrolled in the master's course for at least two years, acquire at least 40 credits in the prescribed subjects, receive the necessary research guidance, submit a master's thesis or master's work, and pass the thesis review and final examination. However, for those who have made outstanding achievements, the period of study may be shortened to one year on the condition that they proceed to the doctoral program.

Subject Classification	Credits	Content
Subjects Related to Master's Research (18 credits required)	18	Subjects related to the master's program research
Course Core Subjects	6	Select 6 credits from the core subjects offered by the student's course
Studio Projects	2	Select 2 credits from studio projects
Electives	14	Select from subjects in the Master's Program of the Department of Design, excluding subjects related to master's research
Total	40	

(Notes on Subjects Registration)

For the electives, students may select up to 6 credits from subjects offered by other graduate schools if the academic supervisor deems it necessary.

B. Detailed Course Descriptions

(1) Master's Program [Strategic Design Course]

Classification	Field	Subjects	Credits	Type	Class Format	Hours per week								Common with other courses	Remarks
						Year 1/ Semester 1		Year 1/ Semester 2		Year 2/ Semester 1		Year 2/ Semester 2			
						Spring	Summer	Autumn	Winter	Spring	Summer	Autumn	Winter		
Subjects Related to Master's Research		Special Research on Design I	4	Required	Seminar	4				(4) *					
		Special Research on Design II	4	Required	Seminar				4			(4) *			
		Special Research on Design III	4	Required	Seminar	(4) *				4					
		Special Research on Design IV	4	Required	Seminar				(4) *				4		
		Design Practice	2	Required	Seminar							4			
Core Subjects	Design and Creativity	Serious Game Design 1	1	Elective	Seminar	2				2					MD
	Design and Creativity	Serious Game Design 2	1	Elective	Seminar	2				2					
	Design and Creativity	Connected Design	1	Elective	Lecture/Seminar			2			2				
	Design and Creativity	Design Innovation	1	Elective	Lecture/Seminar				2				2		
	Design and Creativity	Strategic Service Design	1	Elective	Lecture/Seminar				2				2		
	Cultural and Social Design	Producer Principles	1	Elective	Lecture/Seminar	2				2					
	Cultural and Social Design	Design Management	1	Elective	Lecture/Seminar	2				2					
	Cultural and Social Design	Design Marketing	1	Elective	Lecture/Seminar	2					2				
	Cultural and Social Design	Design Project Management	1	Elective	Lecture/Seminar					2			2		
	Cultural and Social Design	Brand Business Design	1	Elective	Lecture/Seminar	2					2				
	Cultural and Social Design	Design Industry 1	1	Elective	Lecture/Seminar				2				2		
	Cultural and Social Design	Design Industry 2	1	Elective	Lecture/Seminar					2				2	
	Cultural and Social Design	Intellectual Property Laws 1	1	Elective	Lecture	2					2				
	Cultural and Social Design	Intellectual Property Laws 2	1	Elective	Lecture				2				2		
Cultural and Social Design	Design Thinking	1	Elective	Seminar	2					2					

	Cultural and Social Design	Lean Startup 1	1	Elective	Seminar	2			2									QREC Subject
	Cultural and Social Design	Lean Startup 2	1	Elective	Seminar		2			2								QREC Subject
	Cultural and Social Design	Lean Startup 3	1	Elective	Seminar			2			2							QREC Subject
	Cultural and Social Design	Lean Startup 4	1	Elective	Seminar				2			2						QREC Subject
Studio Projects		Studio Project I - A	2	Elective	Seminar	4				4								
		Studio Project I - B	2	Elective	Seminar	4				4								
		Studio Project II - A	2	Elective	Seminar		4				4							
		Studio Project II - B	2	Elective	Seminar		4				4							
		Studio Project III - A	2	Elective	Seminar			4				4						
		Studio Project III - B	2	Elective	Seminar			4				4						
		Studio Project IV - A	2	Elective	Seminar				4				4					
		Studio Project IV - B	2	Elective	Seminar				4				4					
Electives	Engineering	Methodology of Design Engineering	1	Elective	Lecture/Seminar			2				2						(Human)
	Design and Creativity	Human Computer Interaction Design	2	Elective	Seminar				2				2					
	Design and Creativity	User Experience Design	1	Elective	Seminar	2				2								
	Design and Creativity	Art Thinking	1	Elective	Seminar		2				2							
	Design and Creativity	Inclusive Design	1	Elective	Seminar			2					2					(Environment)
	Design and Creativity	Societal Design	1	Elective	Seminar				2					2				
	Design and Creativity	Social System Design	1	Elective	Seminar		2					2						
	Cultural and Social Design	Leadership Theories	2	Elective	Lecture/Seminar			2					2					QBS Subject
	Cultural and Social Design	Organizational Behavior	2	Elective	Lecture/Seminar				2					2				QBS Subject
	Common across courses	SD Advanced Project I	2	Elective	Seminar	4					4							
Common across courses	SD Advanced Project II (Strategic Design)	2	Elective	Seminar		4						4						

Common across courses	SD Advanced Project III (Social Design)	2	Elective	Seminar			4				4		
Common across courses	SD Advanced Project IV (Entrepreneur)	2	Elective	Seminar				4				4	
	Design in Japan A	2	Elective	Lecture	2				2				
	Design in Japan B	2	Elective	Lecture			2				2		
	Academic English	2	Elective	Lecture	4				4				
	Internship I	1	Elective	Practice	2	2	2	2	2	2	2	2	
	Internship II	1	Elective	Practice	2	2	2	2	2	2	2	2	
	Internship III	2	Elective	Practice	4	4	4	4	4	4	4	4	
	Special Project on Design I	1	Elective	Lecture	2	2	2	2	2	2	2	2	
	Special Project on Design II	1	Elective	Lecture	2	2	2	2	2	2	2	2	
	Special Project on Design III	1	Elective	Lecture	2	2	2	2	2	2	2	2	
	Special Project on Design IV	1	Elective	Lecture	2	2	2	2	2	2	2	2	
	Special Project on Design V	2	Elective	Lecture	4	4	4	4	4	4	4	4	
	Special Project on Design VI	2	Elective	Lecture	4	4	4	4	4	4	4	4	
	Special Project on Design VII	2	Elective	Lecture	4	4	4	4	4	4	4	4	
	Special Project on Design VIII	2	Elective	Lecture	4	4	4	4	4	4	4	4	
	Core subjects for all courses, including other courses' electives												

* Only students who wish to complete their studies in Master's early are allowed to take "Special Research on Design III" and "Special Research on Design IV" in the first year.

* Only students who failed to take "Special Research on Design I" and "Special Research on Design II" in the first year are allowed to take them in the second year.

* In the case of Autumn enrollment, "Special Research on Design I" and "Special Research on Design III" must be taken in the second semester, and "Special Research on Design II" and "Special Research on Design IV" must be taken in the first semester. The "Design Practice" must be taken in the summer semester.

(2) Master's Program [Environmental Design Course]

Classification	Field	Subjects	Credits	Type	Class Format	Hours per week								Common with other courses	Remarks
						Year 1/ Semester 1		Year 1/ Semester 2		Year 2/ Semester 1		Year 2/ Semester 2			
						Spring	Summer	Autumn	Winter	Spring	Summer	Autumn	Winter		
Subjects Related to Master's Research		Special Research on Design I	4	Required	Seminar	4				(4) *					
		Special Research on Design II	4	Required	Seminar			4				(4) *			
		Special Research on Design III	4	Required	Seminar	(4) *			4						
		Special Research on Design IV	4	Required	Seminar			(4) *			4				
		Design Practice	2	Required	Seminar				4						
Core Subjects	Design Science	Advanced Environmental Chemistry	2	Elective	Lecture			2			2				
	Design Science	Advanced Thermal Environmental Engineering	2	Elective	Lecture			2			2				
	Design Engineering	Advanced Structural Engineering	2	Elective	Lecture	2			2						
	Design Engineering	Advanced Environmental Materials	2	Elective	Lecture			2			2				
	Design Engineering	Advanced Acoustic Environment	2	Elective	Lecture			2			2			(Acoustics)	
	Design Engineering	Acoustic Environment Assessment	2	Elective	Lecture	4			4					(Acoustics)	
	Design Engineering	Advanced Environmental Psychology	1	Elective	Lecture		2			2					
	Design and Creativity	Advanced Architectural Planning Theory	1	Elective	Lecture	2			2						
	Design and Creativity	Advanced Architecture and Building Construction	1	Elective	Lecture		2			2					
	Design and Creativity	Advanced Environmental Conservation	1	Elective	Lecture			2				2			
	Design and Creativity	Advanced Landscape Ecology	1	Elective	Lecture	2			2						
	Design and Creativity	Advanced Landscape Design	1	Elective	Lecture		2			2					
	Cultural and Social Design	Advanced History of Japanese Architecture	1	Elective	Lecture			2				2			
	Cultural and Social Design	Advanced History of Western Architecture	1	Elective	Lecture			2				2			Offered every other year

	Cultural and Social Design	Advanced Heritage Studies	2	Elective	Lecture	2			2					
	Cultural and Social Design	Environmental Policy Assessment	2	Elective	Lecture	2			2					
	Cultural and Social Design	Advanced Environmental Anthropology	2	Elective	Lecture	2			2					
	Cultural and Social Design	Ecological Social Design	1	Elective	Seminar	2			2				(Future)	
	Cultural and Social Design	Environmental Risk Management	1	Elective	Lecture		2			2			(Future)	
	Cultural and Social Design	Philosophy of Design	1	Elective	Lecture			2			2		(Future)	
	Cultural and Social Design	Art History	1	Elective	Lecture				2			2	(Future)	
	Cultural and Social Design	Advanced Environmental Culture Theory	2	Elective	Lecture			2				2		Offered every other year
	Common across courses	Advanced Environmental Design Project A	2	Elective	Seminar	4								
	Common across courses	Advanced Environmental Design Project B	2	Elective	Seminar			4						
Studio Projects		Studio Project I - A	2	Elective	Seminar	4				4				
		Studio Project I - B	2	Elective	Seminar	4					4			
		Studio Project II - A	2	Elective	Seminar		4					4		
		Studio Project II - B	2	Elective	Seminar		4						4	
		Studio Project III - A	2	Elective	Seminar			4					4	
		Studio Project III - B	2	Elective	Seminar			4						4
		Studio Project IV - A	2	Elective	Seminar				4					4
		Studio Project IV - B	2	Elective	Seminar					4				
Electives	Design Science	Advanced Environmental Ergonomics	1	Elective	Lecture/Seminar	2					2			(Human)
	Design Science	Auditory Perception	2	Elective	Lecture			2				2		(Acoustics)
	Design Science	Advanced Psychology of Visual Perception	1	Elective	Seminar		2					2		(MD)
	Design Science	Advanced Color Science	1	Elective	Seminar			2					2	(MD)

Design Science	Statistics and Computer Science	1	Elective	Seminar	2					2						(Human) (Future)
Design and Creativity	Inclusive Design	1	Elective	Seminar			2					2				(SD)
Common across courses	Landscape Design Project	4	Elective	Seminar	4					4						
Common across courses	Strategic Architect Project A	4	Elective	Seminar	4					4						
Common across courses	Strategic Architect Project B	4	Elective	Seminar			4					4				
Common across courses	Global Architect Project	4	Elective	Seminar						4						
Common across courses	Internship for Architect I	3	Elective	Seminar	4											
Common across courses	Internship for Architect II	3	Elective	Seminar						4						
Common across courses	Internship for Architect	4	Elective	Seminar						4						
	Design in Japan A	2	Elective	Lecture	2					2						
	Design in Japan B	2	Elective	Lecture			2					2				
	Academic English	2	Elective	Lecture	4					4						
	Internship I	1	Elective	Practice	2	2	2	2	2	2	2	2	2	2	2	
	Internship II	1	Elective	Practice	2	2	2	2	2	2	2	2	2	2	2	
	Internship III	2	Elective	Practice	4	4	4	4	4	4	4	4	4	4	4	
	Special project on design I	1	Elective	Lecture	2	2	2	2	2	2	2	2	2	2	2	
	Special project on design II	1	Elective	Lecture	2	2	2	2	2	2	2	2	2	2	2	
	Special project on design III	1	Elective	Lecture	2	2	2	2	2	2	2	2	2	2	2	
	Special project on design IV	1	Elective	Lecture	2	2	2	2	2	2	2	2	2	2	2	
	Special project on design V	2	Elective	Lecture	4	4	4	4	4	4	4	4	4	4	4	
	Special project on design VI	2	Elective	Lecture	4	4	4	4	4	4	4	4	4	4	4	
	Special project on design VII	2	Elective	Lecture	4	4	4	4	4	4	4	4	4	4	4	
	Special project on design VIII	2	Elective	Lecture	4	4	4	4	4	4	4	4	4	4	4	

		Core subjects for all courses, including other courses' electives
--	--	---

- * Only students who wish to complete their studies in Master's early are allowed to take "Special Research on Design III" and "Special Research on Design IV" in the first year.
- * Only students who failed to take "Special Research on Design I" and "Special Research on Design II" in the first year are allowed to take them in the second year.
- * In the case of Autumn enrollment, "Special Research on Design I" and "Special Research on Design III" must be taken in the second semester, and "Special Research on Design II" and "Special Research on Design IV" must be taken in the first semester. The "Design Practice" must be taken in the summer semester.

(3) Master's Program [Human Life Design and Science Course]

Classification	Field	Subjects	Credits	Type	Class Format	Hours per week								Common with other courses	Remarks
						Year 1/ Semester 1		Year 1/ Semester 2		Year 2/ Semester 1		Year 2/ Semester 2			
						Spring	Summer	Autumn	Winter	Spring	Summer	Autumn	Winter		
Subjects Related to Master's Research		Special Research on Design I	4	Required	Seminar	4				(4) *					
		Special Research on Design II	4	Required	Seminar		4				(4) *				
		Special Research on Design III	4	Required	Seminar	(4) *			4						
		Special Research on Design IV	4	Required	Seminar			(4) *			4				
		Design Practice	2	Required	Seminar				4						
Core Subjects	Design Science	Applied Ergonomics	1	Elective	Lecture/Seminar	2				2					
	Design Science	Assistive Technology and Science for Life Activity	1	Elective	Lecture/Seminar	2				2					
	Design Science	Advanced Environmental Ergonomics	1	Elective	Lecture/Seminar	2			2				(Environment)		
	Design Science	Advanced Physiological Anthropology	1	Elective	Lecture/Seminar				2			2			
	Design Science	Advanced Brain and Behavioral Physiology A	1	Elective	Lecture/Seminar	2				2					
	Design Science	Advanced Brain and Behavioral Physiology B	1	Elective	Lecture/Seminar	2				2					
	Design Science	Advanced Kansei Science	1	Elective	Lecture/Seminar			2				2			
	Design Science	Statistics and Computer Science	1	Elective	Seminar	2				2				(Environment) (Future)	
	Design Engineering	Design Cognition	1	Elective	Seminar	2					2				Partial Intensive Subject
	Design Engineering	Human Information Engineering	1	Elective	Lecture/Seminar				2			2		(Future) (Acoustics)	
	Design Engineering	Methodology of Design Engineering	1	Elective	Lecture/Seminar		2				2			(SD)	
	Design Engineering	Biomimetics	1	Elective	Seminar	2				2				(Future)	
	Design and Creativity	Public Design	1	Elective	Lecture/Seminar	2				2					
	Design and Creativity	Context Design	1	Elective	Lecture/Seminar	2				2					
	Design and Creativity	Resilience Design	1	Elective	Seminar				2			2		(Future)	
Cultural and Social Design	Communication Design	1	Elective	Lecture/Seminar	2				2						

	Cultural and Social Design	Life Scope Design	2	Elective	Seminar	4				4					Intensive Subject
	Common Course	Advanced Human Life Design	2	Required	Lecture	4				4					
Studio Projects		Studio Project I - A	2	Elective	Seminar	4				4					
		Studio Project I - B	2	Elective	Seminar	4				4					
		Studio Project II - A	2	Elective	Seminar	4				4					
		Studio Project II - B	2	Elective	Seminar	4				4					
		Studio Project III - A	2	Elective	Seminar		4				4				
		Studio Project III - B	2	Elective	Seminar		4				4				
		Studio Project IV - A	2	Elective	Seminar			4				4			
		Studio Project IV - B	2	Elective	Seminar			4				4			
Electives	Design Engineering	Legal Design	1	Elective	Seminar	2				2					Intensive Subject
		Design in Japan A	2	Elective	Lecture	2				2					
		Design in Japan B	2	Elective	Lecture		2				2				
		Academic English	2	Elective	Lecture	4				4					
		Internship I	1	Elective	Practice	2	2	2	2	2	2	2	2	2	
		Internship II	1	Elective	Practice	2	2	2	2	2	2	2	2	2	
		Internship III	2	Elective	Practice	4	4	4	4	4	4	4	4	4	
		Special project on design I	1	Elective	Lecture	2	2	2	2	2	2	2	2	2	
		Special project on design II	1	Elective	Lecture	2	2	2	2	2	2	2	2	2	
		Special project on design III	1	Elective	Lecture	2	2	2	2	2	2	2	2	2	
		Special project on design IV	1	Elective	Lecture	2	2	2	2	2	2	2	2	2	
		Special project on design V	2	Elective	Lecture	4	4	4	4	4	4	4	4	4	
		Special project on design VI	2	Elective	Lecture	4	4	4	4	4	4	4	4	4	
		Special project on design VII	2	Elective	Lecture	4	4	4	4	4	4	4	4	4	

	Special project on design VIII	2	Elective	Lecture	4	4	4	4	4	4	4	4		
	Core subjects for all courses, including other courses' electives													

- * Only students who wish to complete their studies in Master's early are allowed to take "Special Research on Design III" and "Special Research on Design IV" in the first year.
- * Only students who failed to take "Special Research on Design I" and "Special Research on Design II" in the first year are allowed to take them in the second year.
- * In the case of Autumn enrollment, "Special Research on Design I" and "Special Research on Design III" must be taken in the second semester, and "Special Research on Design II" and "Special Research on Design IV" must be taken in the first semester. The "Design Practice" must be taken in the summer semester.

(4) Master's Program [Design Futures Course]

Classification	Field	Subjects	Credits	Type	Class Format	Hours per week								Common with other courses	Remarks
						Year 1/ Semester 1		Year 1/ Semester 2		Year 2/ Semester 1		Year 2/ Semester 2			
						Spring	Summer	Autumn	Winter	Spring	Summer	Autumn	Winter		
Subjects Related to Master's Research		Special Research on Design I	4	Required	Seminar	4						(4) *			
		Special Research on Design II	4	Required	Seminar			4					(4) *		
		Special Research on Design III	4	Required	Seminar	(4) *			4						
		Special Research on Design IV	4	Required	Seminar				(4) *			4			
		Design Practice	2	Required	Seminar					4					
Core Subjects	Design Science	Statistics and Computer Science	1	Elective	Seminar	2					2				(Environment) (Human)
	Design Science	Chronobiology	1	Elective	Seminar	2					2				
	Design Science	Mathematical Modelling A	1	Elective	Seminar	2					2				Offered every other year
	Design Science	Molecular Biology	1	Elective	Lecture/ Seminar	2					2				
	Design Engineering	Design in General Education	1	Elective	Seminar			2				2			Offered every other year
	Design Engineering	Biomimetics	1	Elective	Seminar	2					2				(Human)
	Design Engineering	Biomaterial Engineering	1	Elective	Lecture/ Seminar	2					2				
	Design and Creativity	Contemporary Art Practice	1	Elective	Seminar			2				2			
	Design and Creativity	Editorial and Information Design Theory	1	Elective	Seminar	2					2				Intensive Subject
	Design and Creativity	Resilience Design	1	Elective	Seminar				2				2		(Human)
	Design and Creativity	Sustainable Design	1	Elective	Seminar			2				2			Intensive Subject
	Cultural and Social Design	Arts and Research	1	Elective	Seminar	2					2				
	Cultural and Social Design	Arts Management	1	Elective	Seminar	2					2				
	Cultural and Social Design	Ecological Social Design	1	Elective	Seminar	2					2				(Environment)
	Cultural and Social Design	Environmental Risk Management	1	Elective	Lecture	2					2				(Environment)

	Cultural and Social Design	Philosophy of Design	1	Elective	Lecture	2				2				(Environment)	
	Cultural and Social Design	Aesthetics of Images	1	Elective	Seminar	2				2					
Studio Projects		Studio Project I - A	2	Elective	Seminar	4				4					
		Studio Project I - B	2	Elective	Seminar	4				4					
		Studio Project II - A	2	Elective	Seminar	4				4					
		Studio Project II - B	2	Elective	Seminar	4				4					
		Studio Project III - A	2	Elective	Seminar		4				4				
		Studio Project III - B	2	Elective	Seminar		4				4				
		Studio Project IV - A	2	Elective	Seminar			4					4		
		Studio Project IV - B	2	Elective	Seminar			4					4		
Electives	Design Science	Mathematical Modelling B	1	Elective	Seminar	2				2					Offered every other year
	Design Engineering	Human Information Engineering	1	Elective	Lecture/ Seminar			2				2	(Human) (Acoustics)		
	Design Engineering	Curriculum and Management for Design Education	1	Elective	Seminar		2				2				Offered every other year
	Design and Creativity	Life and Art	1	Elective	Lecture	2				2					
	Design and Creativity	Speculative Design	1	Elective	Seminar	2				2					Offered every other year
	Design and Creativity	Design Civic	1	Elective	Seminar	2				2					Offered every other year
	Cultural and Social Design	Cultural Policy	1	Elective	Seminar			2				2			
	Cultural and Social Design	Art History	1	Elective	Lecture			2				2	(Environment)		
		Design in Japan A	2	Elective	Lecture	2				2					
		Design in Japan B	2	Elective	Lecture		2				2				
		Academic English	2	Elective	Lecture	4				4					
		Internship I	1	Elective	Practice	2	2	2	2	2	2	2	2		

	Internship II	1	Elective	Practice	2	2	2	2	2	2	2	2		
	Internship III	2	Elective	Practice	4	4	4	4	4	4	4	4		
	Special project on design I	1	Elective	Lecture	2	2	2	2	2	2	2	2		
	Special project on design II	1	Elective	Lecture	2	2	2	2	2	2	2	2		
	Special project on design III	1	Elective	Lecture	2	2	2	2	2	2	2	2		
	Special project on design IV	1	Elective	Lecture	2	2	2	2	2	2	2	2		
	Special project on design V	2	Elective	Lecture	4	4	4	4	4	4	4	4		
	Special project on design VI	2	Elective	Lecture	4	4	4	4	4	4	4	4		
	Special project on design VII	2	Elective	Lecture	4	4	4	4	4	4	4	4		
	Special project on design VIII	2	Elective	Lecture	4	4	4	4	4	4	4	4		
	Core subjects for all courses, including other courses' electives													

- * Only students who wish to complete their studies in Master's early are allowed to take "Special Research on Design III" and "Special Research on Design IV" in the first year.
- * Only students who failed to take "Special Research on Design I" and "Special Research on Design II" in the first year are allowed to take them in the second year.
- * In the case of Autumn enrollment, "Special Research on Design I" and "Special Research on Design III" must be taken in the second semester, and "Special Research on Design II" and "Special Research on Design IV" must be taken in the first semester. The "Design Practice" must be taken in the summer semester.

(5) Master's Program [Media Design Course]

Classification	Field	Subjects	Credits	Type	Class Format	Hours per week								Common with other courses	Remarks
						Year 1/ Semester 1		Year 1/ Semester 2		Year 2/ Semester 1		Year 2/ Semester 2			
						Spring	Summer	Autumn	Winter	Spring	Summer	Autumn	Winter		
Subjects Related to Master's Research		Special Research on Design I	4	Required	Seminar	4							(4) *		
		Special Research on Design II	4	Required	Seminar		4						(4) *		
		Special Research on Design III	4	Required	Seminar	(4) *			4						
		Special Research on Design IV	4	Required	Seminar			(4) *			4				
		Design Practice	2	Required	Seminar				4						
Core Subjects	Design Science	Advanced Psychology of Visual Perception	1	Elective	Seminar	2					2			(Environment)	
	Design Science	Advanced Color Science	1	Elective	Seminar		2				2			(Environment)	
	Design Science	To Learn the Way of Thinking Psychologically for Graduate Students	1	Elective	Seminar			2				2			
	Design Engineering	Computer Science	1	Elective	Seminar	2				2					Intensive Subject
	Design Engineering	Advanced Visual Media Design	1	Elective	Seminar			2				2			
	Design Engineering	Advanced Image Information Processing System Design	1	Elective	Seminar		2				2				
	Design Engineering	Intelligent Design of Visual Environment	1	Elective	Seminar			2				2			
	Design Engineering	Advanced Computer Graphics	1	Elective	Seminar		2				2				
	Design Engineering	Advanced Mechanics Design	1	Elective	Seminar	2				2					
	Design Engineering	Advanced Media Services	1	Elective	Seminar		2				2				
	Design Engineering	Advanced Virtual Reality	1	Elective	Seminar		2				2				Partial Intensive Subject
	Design and Creativity	Media Arts	1	Elective	Lecture/Seminar		2				2				
	Design and Creativity	Advanced Visual Sign	1	Elective	Lecture/Seminar	2				2					
	Design and Creativity	Lecture of Graphic Design	1	Elective	Seminar	2					2				
	Design and Creativity	Advanced Lecture of Content Design	1	Elective	Seminar	2					2				

	Design and Creativity	Serious Game Design 1	1	Elective	Seminar	2					2						(SD)		
	Design and Creativity	History of Film Expression	1	Elective	Seminar	2					2								
	Design and Creativity	Advanced Plastic Arts	1	Elective	Lecture/Seminar	2					2								
	Cultural and Social Design	Theater and Dramaturgy	1	Elective	Seminar	2					2								
	Cultural and Social Design	Current Topics in Multimodal Communication	1	Elective	Lecture/Seminar	2					2								
Studio Projects		Studio Project I - A	2	Elective	Seminar	4					4								
		Studio Project I - B	2	Elective	Seminar	4					4								
		Studio Project II - A	2	Elective	Seminar	4					4								
		Studio Project II - B	2	Elective	Seminar	4					4								
		Studio Project III - A	2	Elective	Seminar			4					4						
		Studio Project III - B	2	Elective	Seminar			4					4						
		Studio Project IV - A	2	Elective	Seminar				4						4				
		Studio Project IV - B	2	Elective	Seminar				4						4				
Electives	Common across courses	Media Design Presentation	2	Elective	Seminar									2					
		Design in Japan A	2	Elective	Lecture	2					2								
		Design in Japan B	2	Elective	Lecture			2						2					
		Academic English	2	Elective	Lecture	4					4								
		Internship I	1	Elective	Seminar	2	2	2	2	2	2	2	2	2	2	2	2		
		Internship II	1	Elective	Seminar	2	2	2	2	2	2	2	2	2	2	2	2		
		Internship III	2	Elective	Seminar	4	4	4	4	4	4	4	4	4	4	4	4		
		Special project on design I	1	Elective	Lecture	2	2	2	2	2	2	2	2	2	2	2	2		
		Special project on design II	1	Elective	Lecture	2	2	2	2	2	2	2	2	2	2	2	2		
		Special project on design III	1	Elective	Lecture	2	2	2	2	2	2	2	2	2	2	2	2		
		Special project on design IV	1	Elective	Lecture	2	2	2	2	2	2	2	2	2	2	2	2		

	Special project on design V	2	Elective	Lecture	4	4	4	4	4	4	4	4		
	Special project on design VI	2	Elective	Lecture	4	4	4	4	4	4	4	4		
	Special project on design VII	2	Elective	Lecture	4	4	4	4	4	4	4	4		
	Special project on design VIII	2	Elective	Lecture	4	4	4	4	4	4	4	4		
	Core subjects for all courses, including other courses' electives													

- * Only students who wish to complete their studies in Master's early are allowed to take "Special Research on Design III" and "Special Research on Design IV" in the first year.
- * Only students who failed to take "Special Research on Design I" and "Special Research on Design II" in the first year are allowed to take them in the second year.
- * In the case of Autumn enrollment, "Special Research on Design I" and "Special Research on Design III" must be taken in the second semester, and "Special Research on Design II" and "Special Research on Design IV" must be taken in the first semester. The "Design Practice" must be taken in the summer semester.

(6) Master's Program [Acoustic Design Course]

Classification	Field	Subjects	Credits	Type	Class Format	Hours per week								Common with other courses	Remarks
						Year 1/ Semester 1		Year 1/ Semester 2		Year 2/ Semester 1		Year 2/ Semester 2			
						Spring	Summer	Autumn	Winter	Spring	Summer	Autumn	Winter		
Subjects Related to Master's Research		Special Research on Design I	4	Required	Seminar	4					(4) *				
		Special Research on Design II	4	Required	Seminar			4				(4) *			
		Special Research on Design III	4	Required	Seminar	(4) *			4						
		Special Research on Design IV	4	Required	Seminar			(4) *			4				
		Design Practice	2	Required	Seminar				4						
Core Subjects	Design Science	Auditory Perception	2	Elective	Lecture			2				2		(Environment)	
	Design Science	Advanced Auditory Physiology	2	Elective	Lecture			2				2			
	Design Science	Time Perception	2	Elective	Lecture			2				2			
	Design Science	Speech Production	2	Elective	Lecture	2				2					
	Design Engineering	Speech Information Processing	2	Elective	Lecture/Seminar				4				4		
	Design Engineering	Advanced Acoustical Control	2	Elective	Lecture	4				4					
	Design Engineering	Advanced Acoustical Engineering	2	Elective	Lecture		4				4				
	Design Engineering	Computational Acoustics	2	Elective	Lecture				4				4		
	Design Engineering	Audiology	2	Elective	Lecture/Seminar			2				2			
	Design Engineering	Acoustic Imaging	2	Elective	Lecture			2				2			
	Design Engineering	Advanced Acoustic Signal Processing	2	Elective	Lecture	2				2					
	Design Engineering	Advanced Acoustic Environment	2	Elective	Lecture			2				2		(Environment)	
	Design Engineering	Acoustic Environment Assessment	2	Elective	Lecture	4				4				(Environment)	
	Design and Creativity	Sound Art	2	Elective	Seminar		4				4				
	Design and Creativity	Composition	2	Elective	Seminar			2				2			
Design and Creativity	Sound Design	2	Elective	Lecture/Seminar			4				4				
Cultural and Social Design	Ethnomusicology	2	Elective	Seminar	2				2						

	Cultural and Social Design	Music Culture in Society	2	Elective	Lecture	2				2										
	Cultural and Social Design	Auditory Culture	2	Elective	Lecture				4					4					Offered every other year	
	Cultural and Social Design	Linguistics	2	Elective	Lecture				4					4					Offered every other year	
	Common across courses	Invited Talks on Acoustic Design	2	Required	Lecture			2					2							
	Common across courses	Readings for Acoustic Design	2	Required	Seminar	2					2									
Studio Projects		Studio Project I - A	2	Elective	Seminar	4					4									
		Studio Project I - B	2	Elective	Seminar	4					4									
		Studio Project II - A	2	Elective	Seminar		4						4							
		Studio Project II - B	2	Elective	Seminar		4						4							
		Studio Project III - A	2	Elective	Seminar			4						4						
		Studio Project III - B	2	Elective	Seminar			4						4						
		Studio Project IV - A	2	Elective	Seminar				4						4					
		Studio Project IV - B	2	Elective	Seminar				4						4					
Electives	Design Engineering	Human Information Engineering	1	Elective	Lecture/Seminar					2					2				(Human) (Future)	
	Common across courses	Advanced Engineering Technology for Auditoriums	2	Elective	Lecture			2					2							
	Common across courses	Exercises in Engineering Technology for Auditoriums	2	Elective	Seminar	2		2		2			2							
		Design in Japan A	2	Elective	Lecture	2					2									
		Design in Japan B	2	Elective	Lecture			2						2						
		Academic English		2	Elective	Lecture	4					4								
		Internship I		1	Elective	Practice	2	2	2	2	2	2	2	2	2	2	2	2		
		Internship II		1	Elective	Practice	2	2	2	2	2	2	2	2	2	2	2	2		
		Internship III		2	Elective	Practice	4	4	4	4	4	4	4	4	4	4	4	4		

	Special project on design I	1	Elective	Lecture	2	2	2	2	2	2	2	2		
	Special project on design II	1	Elective	Lecture	2	2	2	2	2	2	2	2		
	Special project on design III	1	Elective	Lecture	2	2	2	2	2	2	2	2		
	Special project on design IV	1	Elective	Lecture	2	2	2	2	2	2	2	2		
	Special project on design V	2	Elective	Lecture	4	4	4	4	4	4	4	4		
	Special project on design VI	2	Elective	Lecture	4	4	4	4	4	4	4	4		
	Special project on design VII	2	Elective	Lecture	4	4	4	4	4	4	4	4		
	Special project on design VIII	2	Elective	Lecture	4	4	4	4	4	4	4	4		
	Core subjects for all courses, including other courses' electives													

- * Only students who wish to complete their studies in Master's early are allowed to take "Special Research on Design III" and "Special Research on Design IV" in the first year.
- * Only students who failed to take "Special Research on Design I" and "Special Research on Design II" in the first year are allowed to take them in the second year.
- * In the case of Autumn enrollment, "Special Research on Design I" and "Special Research on Design III" must be taken in the second semester, and "Special Research on Design II" and "Special Research on Design IV" must be taken in the first semester. The "Design Practice" must be taken in the summer semester.

4. Requirements for Completion of the Doctoral Program in the Department of Design

A. Completion Requirements

As shown in the table on page 34, students must be enrolled in the doctoral course for the prescribed period of time, acquire at least 10 credits in the prescribed subjects, receive the necessary research guidance, and pass the doctoral thesis review and final examination. However, the period of study may be shortened for those who have made outstanding achievements.

Subject Classification	Credits	Content
Academic Writing Subjects (4 credits required)	4	Subjects related to thesis writing
Direct Research Subjects (6 credits required)	6	Subjects related to doctoral research
Total	10	

B. Doctoral Course Detailed Description

Classification	Subjects	Credits	Type	Class Format	Hours per week						Remarks
					Year 1/ Semester 1	Year 1/ Semester 2	Year 2/ Semester 1	Year 2/ Semester 2	Year 1/ Semester 1	Year 1/ Semester 2	
Academic Writing Subjects	Professional Research Training I	2	Required	Seminar	2		2		2		
	Professional Research Training II	2	Required	Seminar		2		2		2	
Direct Research Subjects	Research Project I	2	Required	Seminar	2		2		2		
	Research Project II	2	Required	Seminar			2		2		
	Research Project I	2	Required	Seminar					2		

5. About Taking the Subject

(1) Timetable

The timetable will be distributed at the beginning of the academic year at the Academic Affairs Section, Student Affairs Division (also posted on the website for students at the Graduate School of Design). If there are any changes to the timetable during the semester (e.g., changes in class periods or classrooms), please note that they will be posted on the bulletin board in the Student Affairs Division. Please see page 51 for the location of the bulletin board.

Period		1	2	3	4	5
School Hours	Start	8 : 40	10 : 30	13 : 00	14 : 50	16 : 40
	End	10 : 10	12 : 00	14 : 30	16 : 20	18 : 10

<https://std.design.kyushu-u.ac.jp/education/timetable/>



(2) Academic Calendar

The Academic Calendar is posted on the bulletin board of the Student Affairs Division and the website for students at the Graduate School of Design.

The schedule includes the start and end dates of classes, summer and winter vacation periods, and days when classes are held on alternative days.

<https://std.design.kyushu-u.ac.jp/education/calendar/>



(3) Subject Registration

1) Students who wish to register for the subjects, please register through the Student Portal System during the registration period indicated on the bulletin board of the Student Affairs Division according to the "Guide to Using the Student Portal System" distributed at the time of admission. Please also register for intensive subjects during the subject registration period.

2) At the beginning of the academic year, a guidance session will be held to inform students of the important information regarding the new academic year, so please make sure to attend the session.

(4) Notes on Subject Registration

Students who register for subjects should note the following.

- 1) Duplicate registration is not allowed for subjects that are offered during the same period in the timetable.
- 2) In principle, changing subject registration is not allowed after the registration confirmation period.
- 3) Students who registered for subjects but did not actually take them will receive a failing grade. Please contact the Academic Affairs Section, Student Affairs Division, Graduate School of Design during the subject registration confirmation period if you wish to de-register a subject. If the student is unable to de-register the subject during this period, the student should apply to the Academic Affairs Section, Student Affairs Division, Graduate School of Design, two weeks prior to the examination period.

(5) Cancellation of Classes Due to Natural Disasters

The Graduate School of Design has established the necessary measures for canceling classes due to typhoons, snowfall, earthquakes, etc.



https://std.design.kyushu-ac.jp/media/cancel_class_due_to_natural_disaster.pdf

(6) Absence from Classes and Examinations

Attendance at classes and regular examinations is checked and managed by the instructor in charge of each subject and is reflected in the assessment.

“Notice of Absence” forms are available in the Academic Affairs Section, Student Affairs Division. It is also posted on the Graduate School of Design website for students.

<https://std.design.kyushu-u.ac.jp/education/authorized-absence/>
(Only in Japanese)



- 1) If students are absent or late for an unavoidable reason, please contact the subject instructor directly.
- 2) Absences from classes, etc. for the following reasons will be recognized as authorized absences.
 - i) When students contract an infectious disease such as a new strain of influenza (infectious disease as defined in Article 18 of the School Health and Safety Law Enforcement Regulations).
 - ii) When there is a risk of contracting an infectious disease such as a new type of influenza, the university instructs the students not to attend school.
 - iii) When students go to court as a candidate for a judge or when students are engaged in duties as a judge.
 - iv) When a relative within the second degree of kinship dies (in principle, for a maximum of one week).
 - v) In the event of a natural disaster or transportation disruption.

Please check with the Academic Affairs Section, Student Affairs Division, for details. Please note that absences for reasons other than those listed above will not be considered authorized absences.

Students may not be treated as absent from classes but may be required to attend make-up classes or submit reports, etc., as instructed by the instructor. Please note that if students fail to take the examination, a follow-up examination may be given under the instructor's instructions. Students must submit a "Notice of Absence" form to be considered an authorized absence.

- 3) If students have an infectious disease such as influenza, their absence will be excused according to the following procedures.
 - i) If students are suspected of having flu, please get a diagnosis at a medical institution.
 - ii) If students are diagnosed with influenza, please contact the Academic Affairs Section of the Student Affairs Division (092-553-4418).
 - iii) Students need to apply for an authorized absence at the Academic Affairs Section of the Student Affairs Division, within 48 hours after the fever has broken. A "Notice of Absence" is required to apply for an authorized absence.
- 4) In the case of absence from regular examinations (except for authorized absences), the Academic Affairs Section of the Student Affairs Division, will contact the teacher in charge of the relevant examination subject if the student notifies the Academic Affairs Section of the Student Affairs Division (092-553-4418) by the start time of the examination.

(7) Syllabus

The syllabus is designed to introduce to students in advance the objectives of the subject, subject outline, lesson plan, textbooks to be used, grading criteria, etc.

The syllabus is available on the Student Portal System. Please read and understand it carefully before registering for subjects to ensure systematic and effective learning.

In principle, the syllabus is prepared and released at the beginning of each academic year, but please note that the content of the syllabus may be changed during the semester at the discretion of the subject instructor. If students have any questions about the syllabus, please contact the Academic Affairs Section of the Student Affairs Division.

<https://ku-portal.kyushu-u.ac.jp/campusweb/top.do>



(8) Examination

There are two types of examinations: regular examinations and supplementary examinations after the regular examinations.

Regular examinations are given at the end of each subject to evaluate students' level of achievement in the subjects.

A supplementary examination is given to students who are unable to take the regular examination due to illness or other unavoidable circumstances. The instructor in charge of the class will decide whether to conduct a follow-up examination, so

students who wish to take a supplementary examination should notify the instructor immediately.

Regular examinations and supplementary examinations are conducted by written examinations. However, depending on the subject, the assessment of works, reports, quizzes, etc., may be substituted for written examinations, so please follow the instructions of the instructor.

(9) Notes on Regular Examinations

The following must be observed when taking regular examinations, etc. (only for written examinations) for subjects offered in the Graduate School of Design.

- 1) Students must bring their student identification cards and display them on their desks during the examination period.
- 2) If students lose or forget their student identification card during the examination period, please contact the Academic Affairs Section of the Student Affairs Division before taking the examination and have them issue a notice of non-possession of student ID card.
- 3) Students must follow the instructions of the supervisor at the examination site.
- 4) Students are not allowed to enter the examination room 20 minutes after the start of the examination. Students are not permitted to leave the examination room before 20 minutes have elapsed from the start of the examination.
- 5) No student can take the examination if he/she has not registered for the course at the beginning of the semester.
- 6) Cheating is strictly prohibited. The disciplinary actions against students who cheat in regular examinations, etc., including expulsion from the university, will be strictly enforced in accordance with the relevant rules and regulations.

(10) Confirmation of Grades and Credits Earned

Grades for subjects are awarded according to the grading criteria stated in the syllabus and are classified as shown in the table below.

In order to confirm the requirements for completion of the subject, students are responsible for checking their credit acquisition and should always be aware of their subject status.

If students have any questions, please feel free to consult with your academic advisor or the Academic Affairs Section of the Student Affairs Division.

Grading (Graduate School)	Grade point (100-point scale)	Pass / Fail
S	90 - 100	Pass
A	80 - 89	
B	70 - 79	
C	60 - 69	
F	- 59	Fail

(11) Period for Confirmation of Grades

The Graduate School of Design has a grade confirmation period after the regular examinations. During this period, inquiries regarding grades for subjects taken during the semester should be submitted to the instructor in charge of the subject. **Please note that any inquiries after this period will not be entertained.**

The specific period will be announced on the bulletin board in late August for the first semester and in early March for the second semester.

If students are dissatisfied with the results of their inquiry to their academic advisor, they may file an appeal. If students wish to appeal, please contact the Academic Affairs Section of the Student Affairs Division within one week after receiving the response from their instructor. **An inquiry/appeal can be made only when there is a clear basis for questioning the grade evaluation. Requests for reevaluation, appeals for relief, or appeals of a pleading nature will not be accepted.**

(12) Internship

Internship is a subject that provides practical and training work experience at companies, government agencies, public-interest corporations, and other organizations to enhance practical skills related to one's future career and to think about one's professional aptitude and future plans while experiencing advanced knowledge and skills in one's own specialized field.

This subject is managed through consultation between the academic advisor and the host institution. Students should consult with their supervising professor to determine the specific method of implementation (timing, contents of study/training at the host institution, etc.).

For details, please refer to the materials distributed in the Academic Affairs Section, Student Affairs Division.

[Internship Process]

- 1) Research and apply to the companies
- 2) Finalize the company for internship and the period and content of the training (matching)
- 3) Purchase the Personal Accident Insurance for Student Pursuing Education and Research (Gakkensai) and liability Insurance coupled with Gakkensai (Futaibaiseiki) for subscribers to Gakkensai or another insurance with the same contents
- 4) Submit the "Pledge Agreement" and "Internship Application Form" (to Academic Affairs Section, Student Affairs Division) (after matching is completed)
- 5) Internship training
(Training period: 1 week to 1 month)
- 6) Submit the "Internship Report" (to Academic Affairs Section, Student Affairs Division)
(Submit to the Academic Affairs Section, Student Affairs Division within two weeks after completing the internship)
- 7) Grading

(13) KIKAN Education Subjects in Graduate School

Kyushu University has been offering "KIKAN Education Subjects in Graduate School" for all graduate students since the academic year of 2015.

The "KIKAN Education subjects in Graduate School" aims to cultivate human resources who can creatively and critically tackle the problems and issues facing modern society and create constructive solutions through free and flexible thinking by acquiring an advanced and broad perspective and thinking ability with the education system cultivated through specialized education in the graduate school. Based on the same concept as the bachelor's degree education, the program further enhances the "ability to look, think, and learn" and the "attitude to seek the truth and continue to learn independently," which have been developed as the "core learning" skills.

Interacting with graduate students from other faculty, whom students would not normally get to know, will be a useful experience. Students are recommended to take at least one subject.

In the Graduate School of Design, up to 6 credits from subjects offered by other graduate schools may be added to the master's degree requirements as electives.

Doctoral students cannot add the credits from these subjects to the completion requirements.

(14) Extension of the Period of Study

The Extension of the Period of Study is a system that allows students, except for those in the second year of the master's program and the third year of the doctoral program, who wish to complete their courses systematically over a certain period of

time beyond the standard course of study due to circumstances such as work commitment, to take courses systematically as specified by the Faculty Council of the Graduate School of Design.

Under this system, the tuition fees to be paid per year until the completion of the program are calculated by dividing the tuition fees for the standard period of study (2 years for the master's course and 3 years for the doctoral course) by the total number of years including the approved extended period of study (3 or 4 years for the master's program and 4, 5, or 6 years for the doctoral program).

For details, please contact the Academic Affairs Section, Student Affairs Division.

6. Submission of Thesis

The degree conferred in the Master's Program of the Graduate School is either **Master of Design** or **Master of Design Strategy**.

The degree to be conferred in the Doctoral Program of the Graduate School is **Doctor of Philosophy in Design** or **Doctor of Engineering**

Please refer to the materials distributed by the Academic Affairs Section, Student Affairs Division, for information on the submission period, guidelines for preparing the thesis, regulations regarding the degree, and the format of the application documents.

[Master's Degree Request Process]

(1) Application for the degree, thesis, etc. (January or June) → (2) Thesis review and final examination (presentation, etc.) → (3) Deliberation on degree conferment → (4) Degree conferment ceremony (late March or late September)

[Doctoral Degree Request Process]

(1) Application for preliminary examination, doctoral thesis, etc. → (2) Preliminary examination → (3) Thesis acceptance decision → (4) Application for Doctoral Thesis review, doctoral thesis, etc. → (5) Thesis Review and final examination (public thesis defense presentation, etc.) → (6) Deliberation on degree conferment → (7) Degree conferment ceremony

[Degree Application Period]

Students may apply for a degree during the academic year.

Master's program Students have the opportunity to apply for the thesis review twice a year (notification will be posted separately).

Doctoral program Students have the opportunity to apply for preliminary examinations four times a year (notification will be posted separately).

(Duration of Doctoral Program)

		Year 1	Year 2	Year 3	Year 4	Year 5
Educational background before advancing or transferring to the doctoral program		Doctoral Program (5 years) 40 credits or more				
Completion of master's program, advance or transfer to the doctoral program	Standard	Master's program (2 years) 30 credits or more		Doctoral Program (3 years) 10 credits or more		
	Shortened	Master's program (2 years) 30 credits or more		Doctoral Program (1 year or more) 10 credits or more		
Completion of a shortened master's program, advance or transfer to the doctoral program	Standard	Master's program (More than 1 year, less than 2 years) Up to 30 credits	Doctoral Program (3 years) 10 credits or more			
	Shortened	Master's program (More than 1 year, less than 2 years) Up to 30 credits	Doctoral Program 10 credits or more		More than 3 years in total	
Those who are recognized as having academic abilities equivalent to or higher than those who hold a master's degree or a professional degree regarding the qualifications for admission to graduate school are transferred to the doctoral program. Students who have completed a professional degree program, advance or transfer to the doctoral program	Standard	Individual Qualification Screening Professional Degree Program (2 years)		Doctoral Program (3 years) 10 credits or more		
	Shortened	Individual Qualification Screening Professional Degree Program (2 years)		Doctoral Program (1 year or more) 10 credits or more		
Completion of law school and advance or transfer to the doctoral program	Standard	Law School (3 years)			Doctoral Program (2 years) 10 credits or more	
	Shortened	Law School (3 years)			Doctoral Program (1 year or more) 10 credits or more	
Completion of a professional degree program with a duration of one year or more but less than two years, transfer to the doctoral program	Standard	Professional degree program (1 year to 2 years)	Doctoral Program (3 years) 10 credits or more			
	Shortened	Professional degree program (1 year to 2 years)	Doctoral Program 10 credits or more		3 years in total	

- * "Standard" refers to cases where the student has entered or transferred to the doctoral program and has completed the standard term of study (3 years), and "Shortened" refers to cases where the term of study has been shortened due to outstanding achievement.
- * In the doctoral program, "advance" means continuing from the master's program to the doctoral program in the Graduate School of Design, and "transfer" means admission to the doctoral program by those who have completed the master's program from other institutions.

7. Professional Certificate Programs

Students who wish to enroll in various programs must notify the Academic Affairs Section of the Students Affairs Division during the registration period indicated on the bulletin board of the Student Affairs Division.

(1) Cultural Hall Management Engineer Training Program

This program fosters human resources with the ability to manage and operate theaters, halls, and other cultural facilities with engineering knowledge of sound, lighting, stage mechanisms, etc., and knowledge of culture and the arts.

The requirements for completion of this program are as follows: students must be enrolled in the master's or doctoral course of the Graduate School of Design and must be approved by the Dean of the Graduate School of Design. Students must earn at least 20 credits, including 14 credits from required subjects. Also, students are required to complete studio project subjects related to the program over two years to complete the program. Upon successful completion of the program, students will receive a certificate of completion.

A. Program Requirement

- a) Acquire 20 credits or more (including 14 credits of required subjects) from the subjects listed on the following page.
- b) At least 2 credits of electives must be earned for each subject group.
- c) The credits earned from available subjects will be counted as credits toward program completion requirements.

B. Subjects

Subject Group	Subject	Graduate School/ Undergraduate School	Credits	Required/ Optional	Remarks
Cultural Hall Art	Ethnomusicology	Graduate School of Design	2	Elective	
	Music Culture in Society	Graduate School of Design	2	Elective	
	Auditory Culture	Graduate School of Design	2	Elective	
	Media Arts	Graduate School of Design	1	Elective	
	Theater and Dramaturgy	Graduate School of Design	1	Elective	
	Advanced Lecture of Content Design	Graduate School of Design	1	Elective	
	Contemporary Art Practice	Graduate School of Design	1	Elective	
Cultural Hall Management	Cultural Policy	Graduate School of Design	1	Required	
	Arts Management	Graduate School of Design	1	Required	
	Philosophy of Design	Graduate School of Design	1	Elective	
	Intellectual Property Laws 1	Graduate School of Design	1	Elective	
	Intellectual Property Laws 2	Graduate School of Design	1	Elective	
	Producer Principles	Graduate School of Design	1	Elective	
	Design Project Management	Graduate School of Design	1	Elective	
Cultural Hall Engineering	Advanced Engineering Technology for Auditoriums	Graduate School of Design	2	Required	
	Exercises in Engineering Technology for Auditoriums	Graduate School of Design	2	Required	
	Room Acoustics	School of Design	2	Elective	
	Acoustic Media Engineering	School of Design	2	Elective	
Common	Studio Project I - B	Graduate School of Design	2	Required	*
	Studio Project II - B	Graduate School of Design	2	Required	*
	Studio Project III - B	Graduate School of Design	2	Required	*
	Studio Project IV - B	Graduate School of Design	2	Required	*

* Students must complete a studio project designated as a related subject to the Cultural Hall Management Engineer Training Program.

(2) Global Architect Program

This program nurtures human resources with design skills who possess engineering knowledge of architecture and environmental design and an understanding of culture and art.

Students who have graduated from the Department of Environmental Design, School of Design, Kyushu University, or from an architecture-related department of another university and who are recognized as having achieved the educational goals of the Department of Environmental Design are eligible to enroll in the Environmental Design Course of the Master Program of the Department of Design, Graduate School of Design, with the approval of the Dean of the Graduate School of Design.

Students who have successfully completed the program will receive a certificate of completion.

This program is accredited by JABEE as a master's degree program in architecture together with graduation from the Department of Environmental Design (or a bachelor's degree program that is recognized as having achieved equivalent educational attainment goals).

A. Program Requirement

- a) Acquire 20 or more credits from the following subjects, including 5 credits of required subjects and 8 or more credits of the required elective subjects.
- b) Complete a master's degree in the course enrolled.

B. Subjects

Subject Group	Subject	Credits	Required/ Optional	Remarks
Studio Project	Global Architect Project	4	Required	
	Strategic Architect Project A	4	Required Elective	
	Strategic Architect Project B	4	Required Elective	
	Studio Project I - A	2	Required Elective	*
	Studio Project I - B	2	Required Elective	*
	Studio Project II - A	2	Required Elective	*
	Studio Project II - B	2	Required Elective	*
	Studio Project III - A	2	Required Elective	*
	Studio Project III - B	2	Required Elective	*
	Studio Project IV - A	2	Required Elective	*
	Studio Project IV - B	2	Required Elective	*
	Landscape Design Project	4	Elective	
Core	Advanced Architectural Planning Theory	1	Required	
	Advanced History of Western Architecture	1	Required Elective	
	Advanced History of Japanese Architecture	1	Required Elective	
	Advanced Environmental Design Project A	2	Required Elective	
	Advanced Environmental Design Project B	2	Required Elective	
	Advanced Environmental Psychology	1	Elective	
	Advanced Architecture and Building Construction	1	Elective	
	Advanced Structural Engineering	2	Elective	
	Advanced Environmental Materials	2	Elective	
Internship	Internship for Architect I	3	Elective	
	Internship for Architect II	3	Elective	
	Internship for Architect	4	Elective	

* Complete a studio project designated as a related subject to the Global Architect Program.

(3) Creative Leadership Program

This program is designed to nurture "advanced design professionals" who excel in the four requirements of design, art, business, and leadership. It aims to cultivate individuals who can conceive long-term visions for society and culture based on creative thinking skills, implement value proposals based on a deep understanding of people and the environment, have empathy for and the ability to collaborate with a diverse range of others in order to implement these values in society, and facilitate innovation projects.

The applicants for this program must be students who are enrolled in the master's or doctoral program of the Graduate School of Design, who the Dean of the Graduate School of Design has approved and acquired 10 credits or more based on the following requirements.

Those who have successfully completed the program will receive a certificate of completion.

A. Program Requirement

- a) At least 10 credits from the subjects on the following page.
- b) At least 1 credit from the Design Engineering or Design and Creativity subjects and at least 1 credit from the Cultural and Social Design subjects in the SD course group.
- c) At least 4 credits from the QBS/QREC subject group.
- d) At least 4 credits from the Collaborative subject group.
- e) The credits earned from available subjects will be counted as credits toward program completion requirements.

B. Subjects

Subject Group	Subjects	Graduate School	Credits	Required/ Optional/	Remarks
SD Course	Serious Game Design 1	Graduate School of Design	1	Elective	Design and Creativity
	Serious Game Design 2	Graduate School of Design	1	Elective	Design and Creativity
	Connected Design	Graduate School of Design	1	Elective	Design and Creativity
	Design Innovation	Graduate School of Design	1	Elective	Design and Creativity
	Strategic Service Design	Graduate School of Design	1	Elective	Design and Creativity
	Producer Principles	Graduate School of Design	1	Elective	Cultural and Social Design
	Design Management	Graduate School of Design	1	Elective	Cultural and Social Design
	Design Marketing	Graduate School of Design	1	Elective	Cultural and Social Design
	Design Project Management	Graduate School of Design	1	Elective	Cultural and Social Design
	Brand Business Design	Graduate School of Design	1	Elective	Cultural and Social Design
	Design Industry 1	Graduate School of Design	1	Elective	Cultural and Social Design
	Design Industry 2	Graduate School of Design	1	Elective	Cultural and Social Design
	Intellectual Property Laws 1	Graduate School of Design	1	Elective	Cultural and Social Design
	Intellectual Property Laws 2	Graduate School of Design	1	Elective	Cultural and Social Design
	Design Thinking	Graduate School of Design/QREC	1	Elective	Cultural and Social Design
	Methodology of Design Engineering	Graduate School of Design	1	Elective	Design Engineering
	Human Computer Interaction Design	Graduate School of Design	2	Elective	Design and Creativity
	User Experience Design	Graduate School of Design	1	Elective	Design and Creativity
	Art Thinking	Graduate School of Design	1	Elective	Design and Creativity
	Inclusive Design	Graduate School of Design	1	Elective	Design and Creativity
Societal Design	Graduate School of Design	1	Elective	Design and Creativity	
Social System Design	Graduate School of Design	1	Elective	Design and Creativity	
QBS/ QREC	Leadership Theories	QBS/ Graduate School of Design	2	Elective	
	Organizational Behavior	QBS/ Graduate School of Design	2	Elective	
	Venture Companies	QBS	2	Elective	
	Innovation Management	QBS	2	Elective	
	Corporate Strategy	QBS	2	Elective	
	Entrepreneurial Opportunity Search	QBS/QREC	2	Elective	
	Industry-Academic Collaboration Management	QBS/QREC	2	Elective	

	Advanced Lecture in Corporate Entrepreneurship	QBS/QREC	2	Elective	
	Technology Marketing Game (Japanese)	QREC	2	Elective	Subject offered in two languages. Choose one if interested.
	Technology Marketing Game (English)	QREC	2	Elective	
	Venture Finance	QREC	2	Elective	
	Applied Entrepreneurship Organization	QREC	2	Elective	
Collaborative	Studio Project I - A	Graduate School of Design	2	Elective	Only for QBS/QREC collaborative projects
	Studio Project I - B	Graduate School of Design	2	Elective	
	Studio Project II - A	Graduate School of Design	2	Elective	
	Studio Project II - B	Graduate School of Design	2	Elective	
	Studio Project III - A	Graduate School of Design	2	Elective	
	Studio Project III - B	Graduate School of Design	2	Elective	
	Studio Project IV - A	Graduate School of Design	2	Elective	
	Studio Project IV - B	Graduate School of Design	2	Elective	
	Lean Startup 1	Graduate School of Design/QREC	1	Elective	
	Lean Startup 2	Graduate School of Design/QREC	1	Elective	
	Lean Startup 3	Graduate School of Design/QREC	1	Elective	
	Lean Startup 4	Graduate School of Design/QREC	1	Elective	
	Global PBL Program	QREC	2	Elective	

8. Qualification

Requirements for Practical Experience in Architecture at Graduate School for the Registration of Architect License

Course: Master's Program, Department of Design, Environmental Design Course

Area of specialization: Design

Years of practice: 2 years or 1 year

The acquisition of the required number of credits as indicated in 1 and 2 below will be recognized as Practical Experience in Architecture required for the registration of Architect License.

Required Credits	
2 years of practical experience	1 year of practical experience
30 credits or more	15 credits or more

1. Internship subjects

Subjects	Credits	Required Credits
Internship for Architect I	3	2 years of practical experience: 14 credits or more 1 year of practical experience: 4 credits or more
Internship for Architect II	3	
Architect Internship	4	
Strategic Architect Project A	4	
Strategic Architect Project B	4	
Global Architect Project	4	

2. Related subjects

Subjects	Credits	Remarks
Advanced Environmental Design Project A	2	8 credits or less
Advanced Environmental Design Project B	2	
Studio Project I - A	2	
Studio Project I - B	2	
Studio Project II - A	2	
Studio Project II - B	2	
Studio Project III - A	2	
Studio Project III - B	2	
Studio Project IV - A	2	
Studio Project IV - B	2	
Advanced Thermal Environmental Engineering	2	8 credits or less
Advanced Structural Engineering	2	

Advanced Environmental Materials	2
Advanced Architectural Planning Theory	1
Advanced Environmental Psychology	1
Advanced Architecture and Building Construction	1
Advanced History of Japanese Architecture	1
Advanced History of Western Architecture	1

9. Doctoral Research Progress Report

(1) Research Progress Presentation

Doctoral students are required to present their research progress at least once a year. Research progress presentations include oral presentations at relevant academic conferences, submission of papers to academic journals, entry in competitions, proposal writing, and other presentations of the results of production and research. Students who have not presented their research outside of the university are required to present their research status at a public presentation attended by multiple faculty members, students, or outside researchers on campus.

(2) Submission of Research Progress Report

Doctoral students are required to fill in the "Research Progress Report" and submit it with related materials to their academic supervisor to report their research progress and receive guidance on their research plan for the next academic year. The deadline for submission of the report will be notified separately.

10. JSPS Research Fellowship for Young Scientists

The "Research Fellowship for Young Scientists" was established by the Japan Society for the Promotion of Science (JSPS) to provide outstanding young researchers with opportunities to devote themselves to research by selecting research themes based on their interest in the early stages of their research careers. Thus, contributing to the development and securing of highly creative researchers who will lead Japan's academic research in the future. The JSPS offers research fellowships to those currently enrolled in a doctoral program or have completed a doctoral program, have outstanding research abilities, and wish to devote themselves to research at a university or other research institution.

If selected, the researcher will be eligible to apply for Grants-in-Aid for Scientific Research (Grant-in-Aid for JSPS Fellows) and receive a research grant upon review. To become a JSPS Research Fellow, you must submit an "Application Form" through

the Research Institution Office when the application opens and pass the first review (written review) and the second review (written review).

Details on how to apply and other information can be found on the JSPS website. The schedule from application to adoption is as follows, but please check the information on the Student Portal for details.

Japan Society for the Promotion of Science Website:

<https://www.jsps.go.jp/j-pd/index.html>



Application Schedule for FY2023 (tentative)

The schedule is as follows. The schedule is subject to change.

Announcement of application guidelines: Mid-February

Notification of internal application period: Early Mar

Deadline for requesting the issuance of electronic application system IDs and passwords: Late April

Deadline for submission of documents Early May

Disclosure of the first review results: Early October

Disclosure of the second review results: Early January

Adoption decision: April 1

<Reference> Research Fellowship for 2023

- Research Fellowship

(1) Research Fellowship- DC (Graduate School Doctoral Program student): Monthly stipend of 200,000 yen

(2) Research Fellowship- PD (Postdoctoral Fellow): Monthly stipend of 362,000 yen

- Research Grant

Research Fellows are eligible to apply for Grants-in-Aid for Scientific Research (Grant-in-Aid for Young Scientists). They will receive a research grant of up to 1.5 million yen each year, in addition to the monthly stipend, after reviewing by the Grants-in-Aid for Scientific Research Committee of the Japan Society for the Promotion of Science (JSPS).

Inquiries

School of Design, General Affairs Division, Research Support Section
(Administration building, 2nd floor, 092-553-4570)

Chapter 2

Student Life at Ohashi Campus

1. Departments Relevant to Students

	Departments	Responsibilities
Student Affairs Division	Academic Affairs Section	Registration for classes, academic and regular examinations, grade management, certificates ¹ , leave of absence, withdrawal and resume studies, thesis review, classroom booking, part-time lecturer, university entrance examination, research students, public lectures, outreach lectures, etc.
	Student Affairs Section	Entrance and tuition fees exemptions, scholarships, study abroad, employment, facilities for extracurricular activities, loaning of equipment, commuter passes ² , consultation service, change of status of residence, etc.
	Global Student Exchange Promotion Center	Provision of information on studying abroad, etc.
	International Office	International matters, etc.
General Affairs Division	General Affairs Section	Part-time job procedures within the university
	Planning and Public Relations Section	Geiko website, official SNS, campus experiences, student works, publicity
	Research Support Section	JSPS Research Fellowship for Young Scientists, Research Ethics Education
Financial Affairs Division	Accounting Section	Payment of students' part-time jobs within the university and account registration
	Supplies Section	Notification of after-hours use of facilities
	Preservation Section for Facilities of Ohashi Campus	Registration of electronic locks (Edy) ²

¹ Official Transcript of Academic Records (Japanese and English), Certificate of Enrollment (Japanese and English), Certificate of Prospective Completion (Japanese and English), and Student Fare Discount Certificate for Commuter Passes are issued by automatic machines.

² The application form (Edy Application Form for Registration (Excel)) for registering electronic locks can be downloaded from the website for students of the Graduate School of Design.

<https://std.design.kyushu-u.ac.jp/life/electroniclock/>



2. Academic Procedures

(1) Standard Period of Study and Limitation Period

	Standard Period of Study	Maximum Period of Study
Master's program	2 years	4 years
Doctoral program	3 years	6 years

The leave of absence period is not included in the period of study.

(2) Leave of Absence, Resume Studies, and Withdrawal

Forms for Leave of Absence, Resume Studies, and Withdrawal are available from the Academic Affairs Section. They are also available on the website for students of the Graduate School of Design.

<https://std.design.kyushu-u.ac.jp/education/leave-reinstatement-withdrawal/>



A. Procedures for Leave of Absence

Students who are unable to study for more than two months due to illness or financial reasons may take a leave of absence with the permission of the Dean of the Graduate School. To take a leave of absence, please consult with the academic supervisor and submit an "Application for Leave of Absence" to the Student Affairs Section. In case of illness, please also submit the doctor's diagnosis.

[Application Period]

If students wish to take a leave of absence for the first semester (from April 1), please apply by the end of February.

If students wish to take a leave of absence for the second semester (from October 1), please apply by the end of August.

Please note that if students apply for a leave of absence before the start of each semester, the tuition fees for the period of the leave will be exempted. However, if students apply for a leave of absence after the start of the semester, the tuition fee for that semester will not be exempted.

B. Procedures for Resume Studies

If students wish to return to the university during the leave of absence, please submit an “Application to Resume Studies.” If the leave of absence has expired, please submit the “Notification of Resume Studies.”

[Application Period]

If students wish to return in the second semester (from October 1), please apply by the end of August.

If students wish to return in the first semester (from April 1), please apply by the end of February.

C. Procedures for Withdrawal

If students wish to withdraw from the university, please consult with the academic supervisor and submit an “Application for Withdrawal” to the Academic Affairs Section. However, the withdrawal will not be permitted if the tuition fees has not been paid.

[Application Period]

If students wish to withdraw at the end of the first semester (September 30), please apply by the end of August.

If students wish to withdraw at the end of the second semester (March 31), please apply by the end of February.

(3) Procedures for Changing Your Current Address, Phone Number, E-mail Address, Domicile, Guarantor or Guarantor's Address, Family Name, and Residence Card

If students change their current address, mobile phone number, e-mail address, domicile, guarantor or guarantor's address, family name, or residence card, please notify the Student Affairs Section, Student Affairs Division.

(4) Payment of Tuition Fees

Tuition fees for each semester must be paid during the following period. The tuition fees for the second semester can be paid in April upon request.

A. Payment Periods 1st semester: Apr 1 - May 31

2nd semester: Oct 1 - November 30

B. Payment Method Bank transfer from the student's parent's or guarantor's bank account to the university's bank account

Note:

In principle, tuition fees must be paid by bank transfer. If for some reason, it is difficult to pay the tuition fee by bank transfer, students may pay the fee by counter banking (transfer from the counter of the bank to the university's account).

If students do not pay the tuition fee within the above period, the university will send a reminder to students and their guarantors to pay immediately. If the tuition fee is still not paid, students will be expelled.

If students have any questions about tuition payment or procedures, please contact the Revenue Section, Accounting Division, Finance Department, Kyushu University (+81 (0)92-802-2352).

(5) Other Procedures

In addition to the procedures mentioned above, there are several other procedures that students need to follow. Please refer to the following list. If students have any questions, please feel free to ask the staff of the Student Affairs Division.



Notices and Use of Facilities

Category	Section	Date	Remarks
Application for permission to post notices	Students Affairs Division, Student Affairs Section	Anytime	Can be posted in Building 7
Application for permission to use facilities		3 days before the day of use (excluding Saturdays, Sundays, and public holidays)	In case of applying for the use of facilities for a club activity, etc.
Notification of after-hour use of facilities			In case of applying for use between 21:00 and 9:00 the following morning or on Saturdays, Sundays, and public holidays (excluding the use of laboratories)
Notification of on- and off-campus events		Anytime	Please contact the supervisor
Notification of after-hours use of facilities	Financial Affairs Division, Supplies Section	By 17:00 on the day	In case of using laboratories after 21:00

3. Communication of Information for Students at Ohashi Campus

(1) Dissemination of Information

The university will inform students of important information regarding classes and student life as follows. Please check this page at least once a day.

Methods	Location		
Student Portal System	How to use https://www.kyushu-u.ac.jp/en/education/class/learning/portal 	From PC https://ku-portal.kyushu-u.ac.jp/campusweb/login_shibo.do 	From mobile phone https://ku-portal.kyushu-u.ac.jp/campusweb/sptop.do 
<p>*If students change their address or contact information, please report it to the Student Affairs Section.</p> <p>*Emails from the Student Portal System are sent to the e-mail address allocated by the university by default. Please forward this to the frequently used email address to check them regularly.</p>			
Student Affairs Division Bulletin Board	In front of the Design Commons (for information on classes, tuition fees, student life, employment, study abroad, etc.)		
Course and Department Bulletin Board	Strategic Design Course: 1st floor, Building 7 Environmental Design Course: 2nd floor, Building 2 Human Life Design and Science Course: 2nd floor, Building 1 Design Future Course: 1st floor, Building 7 (tentative) Media Design Course: 2nd floor, Building 2 Acoustic Design Course: 1st floor, Building 3		

Please provide the Student Affairs Section of the Student Affairs Division with the home or mobile number so that students can be contacted directly for urgent matters.

Information	Dissemination Methods
Cancellation of classes, changes in timetable and classrooms, makeup classes, intensive subjects, examinations	- Student Portal System - Bulletin Board in front of the Design Commons (Information related to class)
Reports, assignments, other class-related information	- Bulletin Board in front of the Design Commons (Information related to class) - Course and Department Bulletin Board
Information from department and supervisors	- Course and Department Bulletin Board
Payment of tuition fees, exemption from tuition fees, communication about student life, scholarships	- Bulletin Board in front of the Design Commons (Information related to tuition fees and student life)
Scholarships for international students, information for international students, students studying abroad	- Bulletin Board in front of the Design Commons (Information related to international students and study abroad)
Employment information	- Bulletin Board in front of the Design Commons (Information related to employment) - Course and Department Bulletin Board
Competitions, open call, events, etc.	- Bulletin Board in front of the Design Commons (Information related student life) - Course and Department Bulletin Board

(2) Handling of Mail

The university does not handle mail addressed to individual students or courier services. Please direct mails to deliver to the home address. Mail addressed to recognized student clubs will be placed in the mailbox of each club at the Student Affairs Division. Please check the mailbox regularly.

(3) Telephone Service

The university does not take personal calls for students. It is the student's responsibility to establish a method of contact in case of emergency.

4. Issuance of Certificates

(1) Student ID Card

The student ID card is an important form of identification. It is necessary for taking examinations, adding or changing subject registration, checking grades, and obtaining a commuter pass or student discount card. **Please handle with care to prevent loss or damage.**

In case of loss or damage, please report it to the Student Affairs Section of the Student Affairs Division as soon as possible and have it reissued. A reissue fee of 2,000 yen will be charged.

The student ID card can be used until graduation. However, a new student ID card will be issued if the student is in the university beyond the standard period of study (valid for one year).

(2) Commuter Pass

When purchasing a commuter pass for public transportation, students need to submit a commuter certificate. A form that also serves as an application form for purchase is available at the Student Affairs Section of the Student Affairs Division. Please fill out the form and submit it with the student ID card.

(3) Issuance of Certificates at the Automatic Machine

Certificate of Enrollment, Official Transcript of Academic Records, Certificate of Prospective Completion, Health Certificate, and Student Fare Discount Certificate for Commuter Passes can be issued from the automatic machines located on the Ohashi campus at the Student Affairs Division. Students must apply online in advance. For more details, please refer to the following university website.

Kyushu university website: Certificates

<https://www.kyushu-u.ac.jp/en/education/procedure/certificate>



Please note the following points when using the Student Fare Discount Certificate.

The certificate can be used when students intend to travel by JR train for the following purposes:

- Returning home for holiday or personal matter
- Regular educational activities such as laboratory work, practical training, and examinations
- Special educational activities approved by the university or extracurricular educational activities related to physical education or culture
- Examination for employment or advancement to higher education
- Participation in any field trip or event deemed appropriate by the university
- Treatment of injuries and illnesses or other problems that may interfere with the student's studies
- Accompanying parents on trips

Students who wish to travel **more than 100 km one way** by rail, ship, or bus may purchase a 20% discounted ordinary ticket, valid for three months from the date of issue.

A discounted certificate can be purchased for a round trip. Please do not misuse the ticket.

5. Consultation on Student Life, Study, and Employment Guidance

(1) Academic Consultation

If students have any questions or concerns about the curriculum of the Graduate School or ways to register the subjects, please do not hesitate to consult with the staff of the Student Affairs Section of the Student Affairs Division. If necessary, they will contact the faculty members-in-charge of the class to discuss individual problems that may arise.

(2) Consultation Services

If students have any questions, requests, or uncertainty about who to ask, please feel free to contact the Student Affairs Section of the Student Affairs Division (10:00 to 16:00).

(3) Office Hour System

As part of our educational reform, we have established an “office hour” system. We encourage students to make full use of this system.

It is designed to strengthen relationships between faculty members and students and to help students feel at ease during their studies. Each faculty member sets a certain time (about 90 minutes) during “office hour” on a day that is convenient for them. Students can consult with faculty members from any course or department, regardless of which course or department they belong to. The “office hour” of each faculty member will be indicated in the syllabus.

Please visit the faculty member's laboratory to consult with them when needed. Students can also use the telephone or e-mail to contact them.

(4) Harassment Consultation

Kyushu University has counselors available to respond to complaints about harassment. Consultations with the counselors can be made in person, by telephone, by letter, or by e-mail. Consultations can be made not only with the victim themselves

but also with someone who has been consulted by the victim or with a witnessing third party.

Students' privacy will always be protected, and students will never be penalized for the consultation. For more information, please refer to the Kyushu University website.

<https://www.kyushu-u.ac.jp/ja/university/publication/harassment> (Japanese only)



(5) Study Abroad

Kyushu University encourages students to study abroad through inter-university or inter-departmental student exchange agreements in order to nurture students with an international outlook.

For the exchange program, the period of study is up to one year, with the exception of some student exchange partner universities. Students do not have to pay tuition fees, examination fees, or admission fees to the host university at their destination as long as students are enrolled at Kyushu University and pay the tuition fees.

In addition, the credits earned at the host university and the period of study will be treated as graduation requirements at Kyushu University. However, the Graduate School of Design will decide to what extent the credits will be approved (credit transfer).

Students who study abroad at non-partner universities are required to pay tuition fees to the host university. Depending on the length of the study abroad period, it may be necessary to take a leave of absence. As in the case of exchange programs, the credits earned are subject to review and approval.

(English Community Space)

Since 2014, the English Community Space has been established on the Ohashi Campus as an initiative to promote internationalization, and Japanese and international students have been engaging in multicultural exchange through various events. The idea behind the English Community Space is to promote multicultural exchange in the same way as Japanese "nabe" cooking, a dish with a mixture of various ingredients.

For example, there are many events such as cooking nights and introducing foreign cultures and cuisines, that are easy for students to participate in. Information on these events will be posted on the Student Portal, so please feel free to join the events.

(GEIKO GLOBAL International Exchange Portal Site)

The Graduate School of Design has set up a portal site to support students from abroad and students who wish to study abroad at the university.



<https://www.design.kyushu-u.ac.jp/en/international/>

Please contact the Student Affairs Division for more information about exchange programs.

[Contact]

Student Affairs Section

TEL: +81 (0)92 - 553 – 9489

E-mail: gkggakusei@jimu.kyushu-u.ac.jp

Academic Affairs Section

TEL: +81 (0)92 – 553 - 4460

E-mail: gkgkyomu@jimu.kyushu-u.ac.jp

If students have any questions about studying abroad, please contact the Global Student Exchange Promotion Center (1F, Administration Building).

TEL: +81 (0)92 – 553 – 4650

E-mail: gkglobal@design.kyushu-u.ac.jp

For more information about studying abroad, please refer to the following:

<p>Information on study abroad: Global Gateways https://www.isc.kyushu-u.ac.jp/intlweb/study (Japanese only)</p> 	<p>Partner institutions https://www.isc.kyushu-u.ac.jp/intlweb/agreeview/worldmap.php?en=1</p> 
<p>Graduate School of Design Website https://www.design.kyushu-u.ac.jp/en/home/</p> 	<p>Geiko Global https://www.gg.design.kyushu-u.ac.jp/en</p> 

(6) Geiko Student Supporters

A support team consisting of Japanese students and senior international students will help new international students to start their life in Fukuoka smoothly. Being a supporter is a valuable opportunity for international exchange in Japan and a great way to improve foreign language skills and broaden international perspective. If students have any questions about the Geiko Student Supporters, please contact the International Office.

International Office (1F, Administration Building)

TEL: +81 (0)92-553-4652

E-mail: intl-ofc@design.kyushu-u.ac.jp

6. Others

(1) Regular Health Checkups for Students

In April each year, regular health checkups are held in the hospital and Ito campus. Please make sure to go for health checkups. Annual health checkups are required by the School Health and Safety Act. The health certificate is necessary for job hunting. The university will not be able to issue the certificate if students have not had a medical health checkup. Students who have undergone a regular health checkup can receive a Health Certificate (free of charge) from an automatic issuing machine.

Center for Health Sciences and Counseling Website

<https://www.chc.kyushu-u.ac.jp/~webpage/english/?mode=pc>



(2) Employment Support

In the Graduate School of Design, each course and department has a faculty member in charge of employment who provides counseling, guidance, and support. Job offers can be viewed in the file located in the Student Affairs Division.

Job hunting in the Graduate School of Design

- a. Necessary information on job hunting will be provided through the Student Portal Site or on the bulletin board, and in some cases, it will be distributed by the Student Affairs Section of the Student Affairs Division.
- b. Information on job fairs, internships, events, and other information unique to the Graduate School of Design will be regularly distributed and updated through the Student Portal. When searching for information, please refer to the “[Important] Information related to employment and call for design work.”

- c. For job offers at Kyushu University (not designated by the Graduate School), please visit Kyushu University's website. Students can find a list of alumni and other information on job hunting activities on the Kyushu University website.

The list of alumni is also available at the Student Affairs Section of the Student Affairs Division.

- d. If students have any questions about the job search, they can seek advice on the Ohashi campus, on Monday and Wednesday from 12:00 to 16:30 (except from 14:00 to 14:30). Please check with the Student Affairs Section of the Student Affairs Division. The Career and Scholarship Support Division of the Student Affairs Department has been established at Kyushu University to provide general support for job hunting activities, including (1) holding job-hunting guidance and support events, (2) providing various types of job-hunting information, and (3) assigning job-hunting counselors (counselors are dispatched to Ohashi Campus every Monday and Wednesday from 12:00 to 16:00).

<https://www.kyushu-u.ac.jp/en/education/employment/foreign>



(3) Traffic Regulations on Campus

A. Vehicle Entry

In principle, students are not allowed to enter campus by car. Exemptions may be made for students with physical disabilities and working adult graduate students. If students wish to do so, please contact the Student Affairs Section.

If students wish to enter the campus to deliver experimental equipment temporarily, please submit the application form for Temporary Entry Permit to the Student Affairs Section at least 3 days before and obtain approval.

B. Bicycle Parking

Bicycles and motorbikes must be parked in the designated parking areas so that they do not interfere with traffic or educational/research activities on campus. Bicycles and motorbikes that are parked in violation of this rule will be subject to regular enforcement and severe punishment, such as deflation of wheels.

Please refer to the "Bicycle/Motorbike Parking" at the Graduate School of Design website for students below.

<https://std.design.kyushu-u.ac.jp/life/>



(4) Notes on Student Life

The Student Handbook is distributed to students at the time of enrollment to help them avoid and deal with problems in their daily lives.

Please refer to it in case of emergencies. It can also be downloaded from the website.

Kyushu University Website

<https://www.kyushu-u.ac.jp/ja/education/life/pamphlet/>

Campus life handbook

<https://www.isc.kyushu->

[u.ac.jp/intlweb/cmn/data/pdf/Campus_Life_Handbook2018_EN.pdf](https://www.isc.kyushu-u.ac.jp/intlweb/cmn/data/pdf/Campus_Life_Handbook2018_EN.pdf)

List of Contact Details for Advice on All Aspects of Student Life

Contact	Phone Number	Contents of Consultation
Student Affairs Section	092-553-4586	General consultation
Security Office in Ohashi Campus	092-553-4428	Emergency calls for incidents and accidents on holidays and at night
Center for Health Science and Counseling Ohashi Branch	092-553-4581	Health Consultation
Student Support Division	092-802-5961	Malicious solicitations, sightings of drugs, etc.
Student Counseling Section	092-802-5820	General advice on student life and study
Fukuoka City Consumer Affairs Center	092-781-0999	Contract problems, malicious business
Ms. Relief Line	092-632-7830	Consultation on crimes targeting women (Fukuoka Prefectural Police)

7. How to Conduct Proper Research

What is “conducting research”? Before beginning the research, it is first necessary to find out what research has been done on the subject and what is known. First of all, students need to check the results and research achievements of their predecessors who have studied the same or similar subject as their research subject. Students should not ignore the work of their predecessors or only quote what suits them.

For more information on how to conduct proper research, please refer to the following URL on the Kyushu University website.

<https://www.kyushu-u.ac.jp/ja/research/ethics/propulsion/>



In addition, based on the guidelines set by the Minister of Education, Culture, Sports, Science and Technology, Kyushu University provides “Research Ethics Education” through e-learning. When students receive a notification on the student portal, please take the course promptly and submit the certificate of completion.

8. Club Activities

Club activities are voluntary, organized, and continuous activities conducted by students outside the classes, and the university recognizes them for their purpose and content.

For more information, please refer to the “Student Activities” at the Graduate School of Design website for students below.

<https://std.design.kyushu-u.ac.jp/life/>



Formation of Groups (Club Activities) etc.

Category	Section-in-Charge	Date	Remarks
Application for permission to form a student organization	Student Affairs Section	Anytime	Please attach the constitution and list of members.
Application for permission to continue student organization		By the end of March	

9. Use of Ohashi Campus Facilities

The Ohashi Campus is equipped with the following welfare and extracurricular educational facilities. Please refer to the Appendix at the end of this book for the layout of the facilities.

(1) Design Commons

The “Design Commons” is a facility to support student learning, with a cafeteria and a shop on the ground floor. The Center for Health Sciences and Counseling Ohashi Branch is located on the second floor. The active learning space on the second floor can be used when it is not being used exclusively for events.

For more information, please refer to the following URL:

<Manly>

<https://twitter.com/kyushumanly>
(Japanese only)



<coop>

<http://www.coop.kyushu-u.ac.jp/>
(Japanese only)



(2) Center for Health Sciences and Counseling Ohashi Branch

When students enroll in university, they may experience significant changes in their physical and mental health due to changes in their lifestyle and living environment. The university has established the Campus Life and Health Support Center, staffed by doctors, nurses, and clinical psychologists, to provide health checkups, health counseling, emergency treatment, and psychological counseling.

For more information, please refer to the following:

<http://www.chc.kyushu-u.ac.jp/~webpage/english/>



(3) Resting Room for Women

A resting room for women is available on the second floor of the Design Commons for female students and faculty members who need to rest temporarily for reasons such as health problems.

Please contact the General Affairs Section of the General Affairs Division on the second floor of the Administration Building to use this room.

General Affairs Section of the General Affairs Section TEL: +81 (0)92 – 553 – 4400

(4) Design Library

The purpose of the Design Library is to collect, organize, and preserve books, journals, and documents necessary for education and research and make them widely available for academic research and study. In the 2022 academic year, the building will be renovated to improve the aging facilities and enhance their functions. For this reason, the Design Library will be closed at the end of February 2022, but a temporary library will be opened on the first floor of the Co-Lab Building for approximately one year from April of the same year. The new library, after the renovation, is scheduled to open in June 2023 at the same location as the current one.

Please visit the Design Library website for information on the library's services, opening schedule, and events.



(5) Design Workshop

The workshop is used for the production of artworks and design projects, with the aim of acquiring sensitivity to materials and expressive ability, which are important in modeling and design.

The three-story workshop has more than 10 workrooms, including a large workshop, a general workshop, and a welding workshop, each of which is equipped with a wide range of machines for woodworking, metalworking, assembly, and painting.

There are currently more than 20 different types of equipment, more than 100 hand-held power tools, and a wide range of hand tools such as chisels, saws, and hacksaws.

The workshop is equipped with many tools and machine tools. Thus, a certain amount of risk is involved, and experience and skill are required. When using the workshop, please read the following instructions carefully and understand the instructions given by the faculty member or workshop staff.

A. Notes on Use

Basic Safety Precautions

The starting point for safety in practical work is a well-planned preparation for the materials and work content. It is also essential to wear appropriate clothing, know which equipment to use for each task, and have a sense of urgency. While working in the workshop, pay attention not only to own safety but also to others' safety. The work environment needs to be tidy and orderly to avoid injuries and accidents.

a) Clothing

Please wear comfortable clothing suitable for practical work, such as long sleeves and long pants with no cuffs or hems. Short pants, skirts, and other clothing that may compromise safety will not be permitted.

- Work clothes can get dirty with oil, paint, dust, cutting chips, etc.
- When using towels, etc., do not hang them around the neck or waist. Please place them in a pocket or on the worktable. Pendants, neckties, etc., should also be removed as there is a high risk of being caught in the rotating machinery.
- Shoes with slippery soles or sandals are not allowed in the workshop.
- Tie up long hair or use a work cap

b) Working in the Design Workshop

The workshop contains many tools and machines, ranging from simple hand tools to NC machines that automatically perform complex operations. These tools and machines can be used safely by following the correct operating procedures and understanding how they work. However, carelessness, negligence, incorrect knowledge, or incorrect operating procedures can not only damage the equipment but also lead to serious accidents involving the user and other workers in the vicinity.

Before using any of the equipment in the workshop, students must be instructed by a faculty or workshop staff member. Even if students have received instructions, they must obtain permission from the faculty member-in-charge or workshop staff before using the equipment.

- Do not use machines or equipment without permission from the faculty member-in-charge or workshop staff.
 - Always ask the faculty member-in-charge or workshop staff for advice about preparation and work procedure before starting the project or work.
 - Keep the work area free of clutter and remove unnecessary materials, tools, and other objects before starting the work.
 - Incorrect operation of machine tools can lead to severe accidents. Know the operating methods before starting the work.
 - When two or more people are working together, make sure to signal each other to ensure mutual safety before operating the machine.
 - To prevent accidents, students other than those using the machine should stay away.
 - Always wear safety gear to protect from falling objects, high temperature cut pieces, or other hazardous materials, according to the type of work or condition.
 - After the work is done, clean the floor, machines, and equipment used. Once cleaning is done, inform the faculty member-in-charge or the workshop staff and obtain permission to leave.
 - If students do not follow the instructions or their behavior is extremely unsafe, they may be asked to leave the workshop.
 - If students wish to use the workshop during after-hours, they must obtain the faculty member-in-charge's approval.
- * Please refer to the next section, "B. Procedure for Using the Workshop," for procedures and precautions when using the workshop.

c) Color Coding for Machinery Classification

In the workshop, machine tools are color-coded according to the degree of danger, as shown below, and colored stickers are placed on each machine's controls or power

switches. Some machines require experience and skill to operate. Hence, please discuss with the faculty member-in-charge or workshop staff beforehand and use the machine with their permission or in their presence and under their guidance.

- (Red) Highly dangerous, requires specialized knowledge and experience, and in principle, only relevant faculty or workshop staff members are permitted to use it.
- (Orange) Highly dangerous, requires advanced knowledge and experience, and use is permitted only in the presence of a relevant faculty member or workshop staff.
- (Yellow) Dangerous depending on the usage, requires a certain amount of knowledge and experience, and use is permitted under the guidance of a relevant faculty member or workshop staff.
- (Blue) With basic knowledge and experience, use is permitted upon when the request is made to the relevant faculty member or workshop staff.

If students have any questions about the color coding of the equipment or the requirements, please ask faculty member-in-charge or workshop staff.

B. Procedure for Using the Workshop

The workshop is a shared facility for all students. Please be careful when using it, and share tools, machines, and workspace with others. Please read the following guidelines, notes, and procedures before submitting the application.

a) Opening Hours of the Design Workshop

- The workshop is open from 9:00 to 17:00 on weekdays (closed at 16:30 on Fridays). Please stop work 30 minutes before closing time and start cleaning the work areas and equipment used.
- The workshop is closed during the lunch hour (12:00 to 13:00) on weekdays. The use of any machine or tool is prohibited during this hour.
- The workshop is closed on Saturdays, Sundays, National Holidays, and Year-end and New Year holidays.
- Please note that the workshop may not be available due to maintenance or other reasons, even during the available times listed above.

b) Use of Workshop Other Than Class Purpose

During opening hours (weekdays from 9:00 to 17:00, closed at 16:30 on Fridays)

- If students wish to use the facility during opening hours, please apply from the following URL in advance.

<https://forms.gle/wJJPkFgso5dh5QsM6>



- If there is a class using the workshop during the same period, the class will take priority.
- Before using the workshop, please confirm the application's approval from the following URL.

<https://bit.ly/31MIGWF>



- Depending on the work to be done and the machines to be used, a meeting with the supervisor or the workshop staff may be necessary.

After-hours use (after 17:00 on weekdays, after 16:30 on Fridays, and holidays)

- If students wish to use the workshop after hours, please submit an application form to the Workshop Management Office by 17:00 on the day before the day of use. If students wish to use the workshop on the first day after a holiday, they must submit the form before the holiday.
 - Students can continue to work after 17:00 (16:30 on Fridays) to 20:00 under the supervision of the faculty member-in-charge.
 - The faculty member-in-charge is responsible for returning the key to the workshop.
- All other matters are subject to the terms and conditions for use during these hours. For more information, please refer to the "Safety Rules and Regulations in the Design Workshop" at the Graduate School of Design website for students below.

<https://std.design.kyushu-u.ac.jp/life/designworkshop/>



(6) Guide to the Use of the Information Infrastructure Office (Information Infrastructure Initiative Ohashi Office)

A. Introduction

Although the library and the Information Infrastructure Office will not be available for use during the 2022 academic year due to renovation work, an Information Practice Room and an Information Study Room where students can use their laptop computers for learning and education purposes such as lectures, report writing, and information gathering will be available from the 2023 academic year onward. In addition, the Black

Room will be equipped with dedicated terminals for the production, editing, and viewing of audio-visual works.

B. Location and Hours of Educational Terminals

The information on the Information Practice Room, Information Study Room and Black Room will be as follows.

Table 1 Available Rooms

Information Practice Room and Information Study Room

Room	Number of Terminals	Remarks
Information Practice Room (1st floor)	54	Priority to Classes Not available for 2022 due to construction
Information Study Room (2nd floor)	23	Not available for 2022 due to construction

Black Room

Room	Remarks
Black Room 1 (1 st floor)	The room is a soundproof room, which enables advanced editing of video and audio works. (Not available for 2022 due to the construction)
Black Room 2 (2 nd floor)	The room is a soundproof room, which enables advanced editing of video and audio works. (Not available for 2022 due to the construction)

Table 2 Available Time (Tentative)

Information Practice Room and Information Study Room

	Weekdays	Saturdays, Sundays, Holidays
Apr – Jul, Oct – Feb	9:00 – 20:50	Close
Aug, Sep, Mar	9:00 – 16:50	Close

Black Room

	Weekdays	Saturdays, Sundays, Holidays
Jan – Dec	9:00 – 16:50	Close

C. Method of Use (Tentative)

- Information Practice Room and Information Study Room
- Information Practice Room is available for use outside of class hours. The Information Study Room may be used freely.

- Black Room
- The Black Room is available upon reservation.

D. Notes on Usage

- Do not use the room for any purpose other than research and education.
- Do not leave valuables unattended.
- Take care of personal belongings and do not forget anything, since many people come in and out of the building.
- Notices of temporary closures, etc., will be posted near the entrance of the building and on the following website of the Information Infrastructure Office.

Information Infrastructure Office

<https://www.imo.design.kyushu-u.ac.jp/>

(Japanese only)



(7) Physical Education Facilities

The following physical education facilities are available on Ohashi Campus.

The priority of using these facilities is given to classes and official clubs. Therefore, in principle, students are not allowed to use the facilities when they are being used by classes or official clubs.

A. Gymnasium

The opening hours are as follows:

Weekdays: 9 :00 to 21:00

(If students wish to use the gymnasium after hours (after 21:00), please apply to the Student Affairs Section of the Student Affairs Division.)

Saturdays, Sundays, and holidays

The gymnasium is not open. However, if students wish to use it, please make a request to the Student Affairs Section of the Student Affairs Division at least three days before the day of use (excluding Saturdays, Sundays, and holidays).

B. Multipurpose Sports Field

If students wish to use the multipurpose sports field on Saturdays, Sundays, or holidays, please apply to the Student Affairs Section of the Student Affairs Division at least three days before the day of use (excluding Saturdays, Sundays, and holidays).

C. Tennis Court

If students wish to use the tennis courts on Saturdays, Sundays, or holidays, please apply to the Student Affairs Section of the Student Affairs Division at least three days before the day of use (excluding Saturdays, Sundays, and holidays).

10. Safety Guide

This handbook contains a copy of the Safety Guide. For more information, please refer to the Graduate School of Design website for students.

<https://www.isc.kyushu->

[u.ac.jp/intlweb/cmn/data/pdf/Campus_Life_Handbook2018_EN.pdf](https://www.isc.kyushu-u.ac.jp/intlweb/cmn/data/pdf/Campus_Life_Handbook2018_EN.pdf)

(1) Safety Precautions Regarding Campus Life and Research Activities

A. General Safety

- a) Be aware of the location of fire extinguishers, fire hydrants, fire alarms, emergency telephones, and evacuation devices, and be familiar with their operation.
- b) Secure any equipment in student rooms and laboratories that may fall over during an earthquake.
- c) Keep laboratories, experiment room and practice room neat and tidy at all times.
- d) If students have no choice but to stay on campus during the night, take care of their safety when using the university facilities.
 - If students have no choice but to use the facilities after hours (after 21:00), please obtain the consent of the facility manager* and use the facilities appropriately to avoid accidents or noise. In addition, the use of the facilities after midnight or making noise that is out of line with social norms is strictly prohibited.
 - When using the facilities for other purposes, regardless of whether it is during or after hours, please obtain the consent of the facility manager* before using the facilities in an appropriate manner.
- * Facility manager; e.g., laboratories: faculty members, classrooms: Student Affairs Division
- e) Be careful of suspicious persons.
- f) Drinking alcohol

Underage drinking is prohibited by law. Please be careful and make every effort to prevent accidents involving underage drinking. Please refrain from drinking heavily or forcing others to drink. These may result in disciplinary action. In addition, please be careful of the following:

- Do not offer a drink to someone who cannot drink.
- Drink slowly while eating.
- Do not drink too much and stop when feeling "tipsy."
- Never drink and drive.

g) Disciplinary action

Students who violate the rules and regulations of the university or act in a manner contrary to the essential principles may be subject to disciplinary action, such as expulsion, suspension, or given a warning. For example, a student who commits a criminal offense such as theft (burglary, stealing, shoplifting, etc.) will be expelled, suspended, or given a warning; forcing another person to drink alcohol and causing death will be punished with expulsion, suspension, or given a warning. Students who defame others on the internet will be expelled, suspended, or given a warning.

h) Smoking on campus

Smoking is prohibited on Ohashi Campus. Smoking is allowed in off-campus smoking area.

B. General Rules for Research Experiments and Practical Training

https://www.isc.kyushu-u.ac.jp/intlweb/cmn/data/pdf/Campus_Life_Handbook2018_EN.pdf

C. General Guidelines for the Safety of the Test Subjects and the Protection of Right

https://www.isc.kyushu-u.ac.jp/intlweb/cmn/data/pdf/Campus_Life_Handbook2018_EN.pdf

D. General Fire Prevention Tips

https://www.isc.kyushu-u.ac.jp/intlweb/cmn/data/pdf/Campus_Life_Handbook2018_EN.pdf

E. General Rules of Traffic Safety

All students are required to pay attention to traffic safety, obey traffic regulations, and strive to prevent traffic accidents on and off-campus.

If students have caused or have been involved in an accident, they must consult with the Students Affairs Division, Student Affairs Section.

a) On-campus precautions

In order to maintain a quiet environment and ensure the safe movement of pedestrians, please observe the following rules when driving cars, motorbikes, bicycles, and other vehicles on campus:

- Only persons with a disability or working adult graduate students may apply to commute by car and must renew their application each year.
- The vehicle must be driven in accordance with the road signs and at a speed of no more than 15 km/h.
- Parking is prohibited in areas other than parking lots and bicycle parking lots. In particular, parking near fire hydrants and other areas where parking is prohibited is strictly forbidden so as not to interfere with emergency operations.
- Entry into areas outside the designated areas on campus by the university is prohibited.
- Do not leave bicycles, motorbikes, etc., unattended on campus.
- Do not interfere with research or educational activities by unnecessarily honking or revving up.
- Take out voluntary insurance if possible in case of an accident.
- Do not play ball, roller skate, skateboard, etc., on the road or in the open space.

b) Off-campus precautions

In order to avoid traffic accidents, please keep the following points in mind when driving:

- Drive with an awareness that human life is precious.
- Drive with consideration and a willingness to give and receive.
- Drive appropriate to the driving ability.
- Drive when in good physical and mental condition. Be careful about overwork, drinking, illness, using mobile phones, etc.
- Always drive with a calm mind. Be careful of being “hasty and impatient”, “angry”, and “self-centered”.

F. Safety Measures Against Earthquakes

Disasters caused by natural phenomena such as earthquakes, typhoons, torrential rains, and eruptions are known as natural disasters. Earthquakes are the most terrifying of these natural hazards because they can cause a wide range of disasters, including the destruction of structures, fires, landslides, cliff collapses and tsunamis—all of which

can claim many lives in an instant. It is also impossible to predict when, where, and how big such an earthquake will occur. In order for students to protect themselves and reduce the damage, they should always be prepared for an earthquake.

For more information on earthquake safety measures, please refer to the following:

https://www.isc.kyushu-u.ac.jp/intlweb/cmn/data/pdf/Campus_Life_Handbook2018_EN.pdf

G. General Tips for Using Computer Networks

With the spread of the internet in recent years, there have been more opportunities to use computer networks daily and not only for educational or research purposes. Due to the nature of the internet, which is used by many people around the world both inside and outside the university, we must be as careful about the information on the network as we go about it among the general public.

- a) Do not post or disclose personal information or others. Information such as names, addresses, telephone numbers, credit card numbers, etc., may be used not only for commercial purposes but also for criminal purposes.
- b) The exchange of confidential information over a network should be avoided as far as possible, or measures such as encryption should be taken. It may be possible for third parties to receive, process, or fabricate the information being communicated.
- c) Malicious third parties or computer viruses can destroy or tamper with the software and data environment of the computer at hand. Be careful about password management and network login authorization systems and avoid the use of software of unknown origin as much as possible.
- d) Avoid, consciously or unconsciously, any behavior that may contravene the law. For example, keep in mind the following:
 - When creating a website, it is easy to use other people's music, paintings, cartoons, photographs, etc. However, when using copyrighted material, permission should be obtained from the rights holder.
 - Computer programs and materials such as music and pictures are protected as copyrighted works. Do not reproduce them without permission except in certain cases permitted by the law, such as private use.
 - In case of citing other people's papers on the student's website without permission, students must meet all conditions, including the necessity to cite, the students' paper must be the main part and others are secondary, the use of clear quotations (e.g., with an asterisk) and clear attribution of sources.

- As university students, they must strictly refrain from doing anything that violates the law, such as infringing on the privacy of others, slandering others, or distributing obscene images on the internet.
 - Works for which the term of copyright protection has expired (generally 50 years after the author's death), such as ancient documents, may be used freely. In addition, works for which the copyright has been waived may also be used within the scope of the conditions of the waiver.
- e) Do not post anything thoughtlessly on social networking services such as Twitter, as many people can view it. This may lead to social responsibility and may also violate laws such as the Personal Information Protection Law, which may result in disciplinary action.

H. Precautions When Traveling Abroad:

- (a) Submit a notification of overseas travel to the Student Affairs Section.
- (b) Ensure personal safety!
- (c) Avoid unreasonable plans.
- (d) Follow the advice and recommendations of diplomatic missions abroad.
- (e) Seek medical advice on health care and medical supplies before travel.
- (f) If students are involved in an incident or accident, contact the embassy abroad.
- (g) Before traveling abroad, students should register with the Ministry of Foreign Affairs' travel registration service (for less than three months: Tabiregi; for more than three months: Zairyutodoke).

<https://www.ezairyu.mofa.go.jp> (Japanese only)



(2) What to Do in an Emergency

https://www.isc.kyushu-u.ac.jp/intlweb/cmn/data/pdf/Campus_Life_Handbook2018_EN.pdf

(3) Safety Precautions for Extracurricular Activity

https://www.isc.kyushu-u.ac.jp/intlweb/cmn/data/pdf/Campus_Life_Handbook2018_EN.pdf

11. Reporting of Award Information

If students' work, thesis, or research results obtain an award in a competition, please report it to the academic supervisor. We would like to use the information for student awards in the department and publish it on the Graduate School of Design website.

The report form is available on the Graduate School of Design website. Please download the form, fill it out, and submit it to the academic supervisor.

Award Information Report

<https://std.design.kyushu-u.ac.jp/life/>



Appendix



1. Campus Map

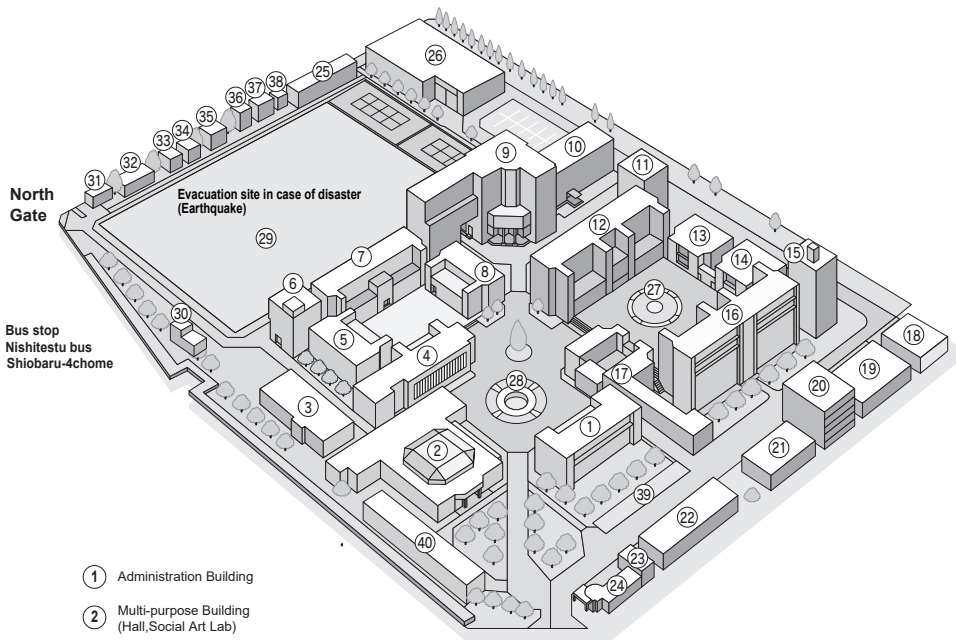

- ① Administration Building
- ② Multi-purpose Building (Hall, Social Art Lab)
- ③ Information Infrastructure Office (Information Infrastructure Initiative Ohashi Office)
- ④ Design Library
- ⑤ Building 8
- ⑥ Global Innovation Center (GIC) Advanced Design Project Building
- ⑦ Building 7
- ⑧ Building 6
- ⑨ Building 5
- ⑩ Co-Lab Building
- ⑪ Building 4
- ⑫ Building 2
- ⑬ Visual Communication Design Center
- ⑭ Acoustic Research Center
- ⑮ Building 3
- ⑯ Building 1
- ⑰ Design Workshop
- ⑱ Environmental Research Center
- ⑲ Printing Workshop
- ⑳ Open Design Laboratory
- ㉑ Research Center for Human Environmental Adaptation
- ㉒ Utilities Building
- ㉓ Parking Garage
- ㉔ Security Office
- ㉕ Club Activities Building
- ㉖ Gymnasium
- ㉗ Frying Pan
- ㉘ Fountain
- ㉙ Multipurpose Sports Field
- ㉚ Experimental House for Living Space Design
- ㉛ Garbage Collection Point
- ㉜ Garbage Collection Point
- ㉝ Waste Liquid Storage
- ㉞ Warehouse
- ㉟ Student Union Room
- ㊱ Stockpile
- ㊲ Warehouse for Students
- ㊳ Warehouse
- ㊴ Motorcycle Parking Area
- ㊵ Design Commons

☞ **Main Gate**
to Nishitestu Ohashi Station

(Cafeteria and Shop,
Center for Health Sciences and
Counseling Ohashi Branch,
Health Consultation·Student Counseling)

※ For bicycle parking, please refer to the website for students of the Faculty of Design.
Student Portal <http://std.design.kyushu-u.ac.jp>
[Student Support] → [Bicycle/Motorcycle parking]



2. Floor Plan of Each Building and Facility

(Please note that the faculty member's room may change due to faculty changes.)

(As of March 2022)

Building 1

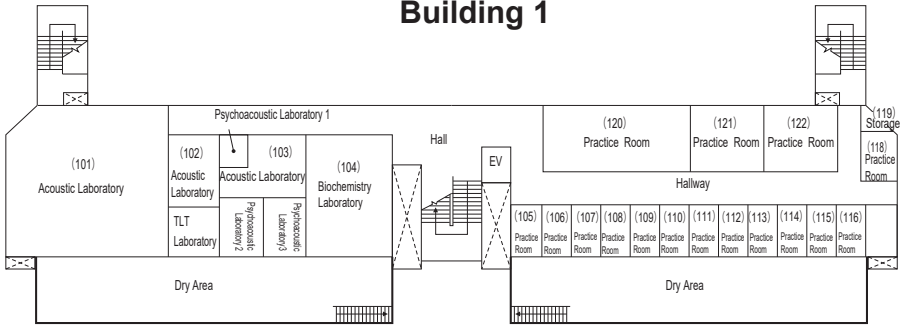

First Floor

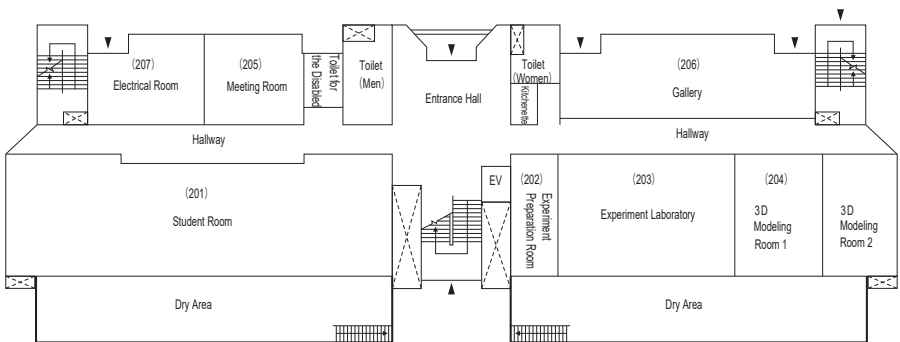

Second Floor

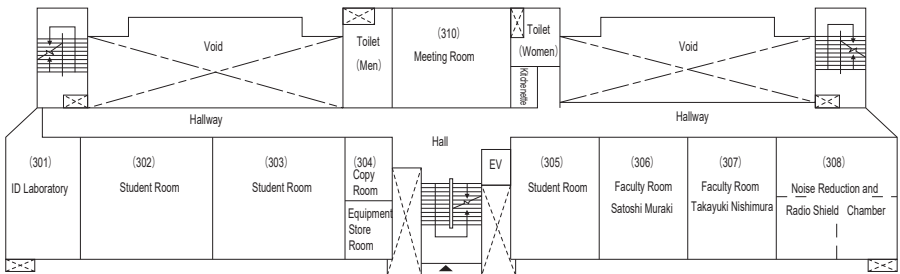

Third Floor

Building 1

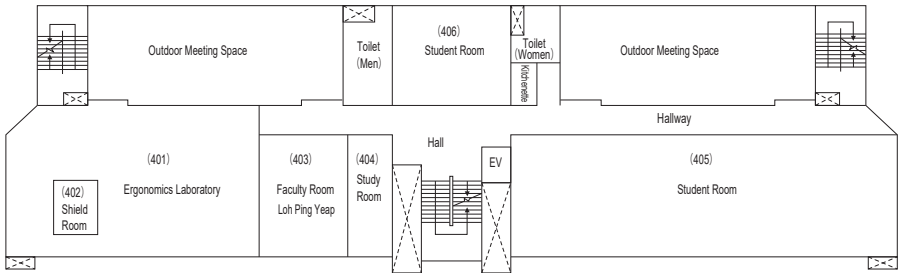

Fourth Floor

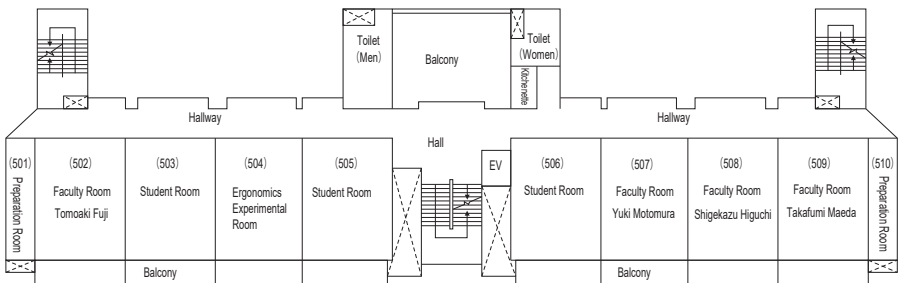

Fifth Floor

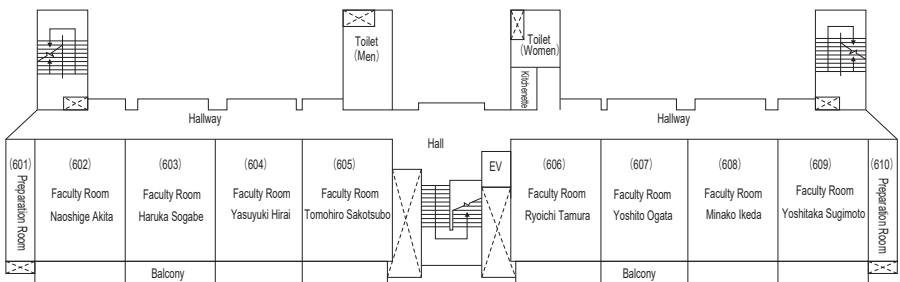

Sixth Floor

Building 2

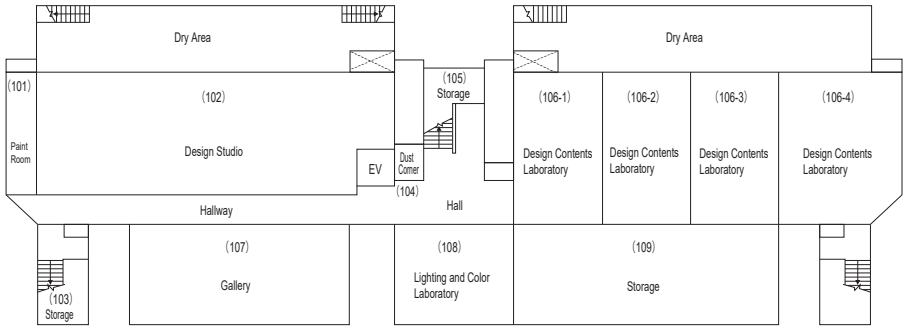

First Floor

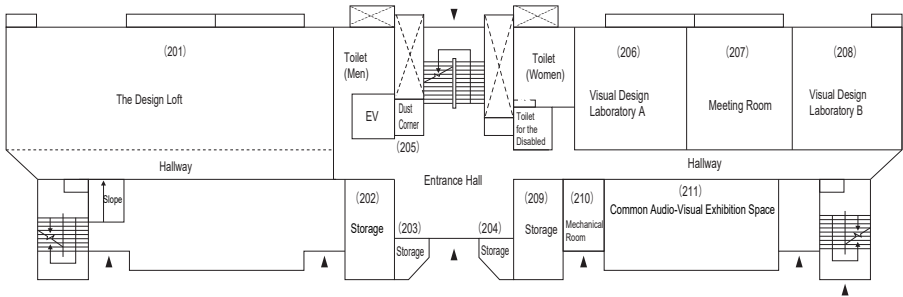

Second Floor

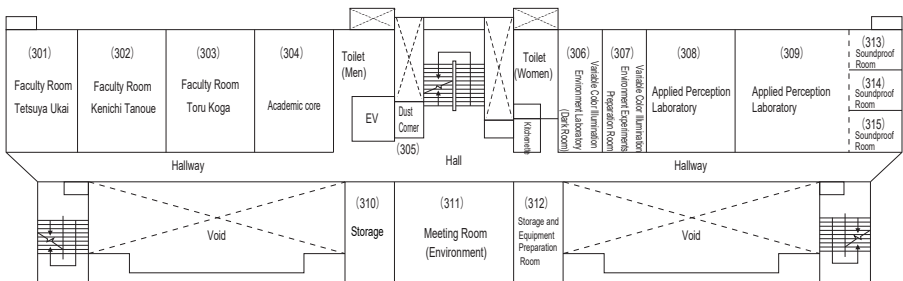

Third Floor

Building 2

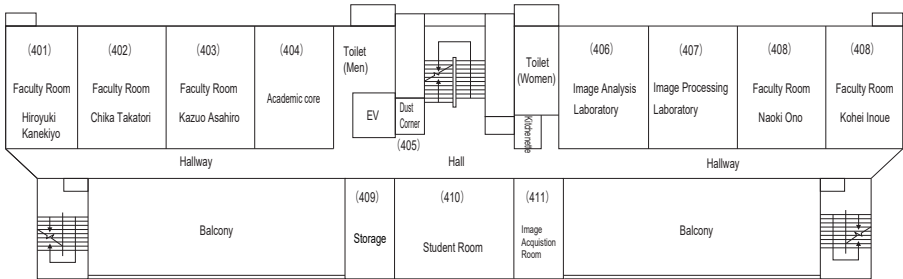

Fourth Floor

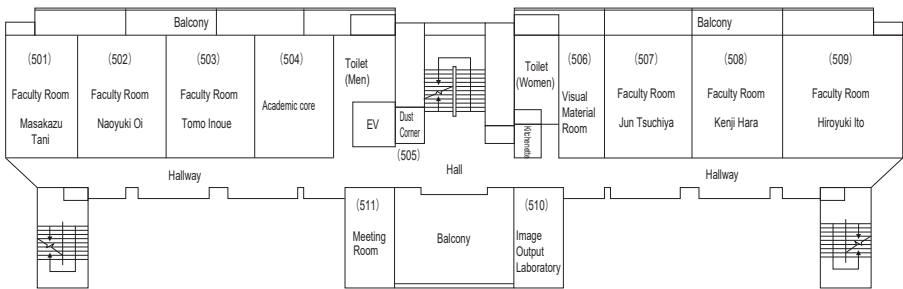

Fifth Floor

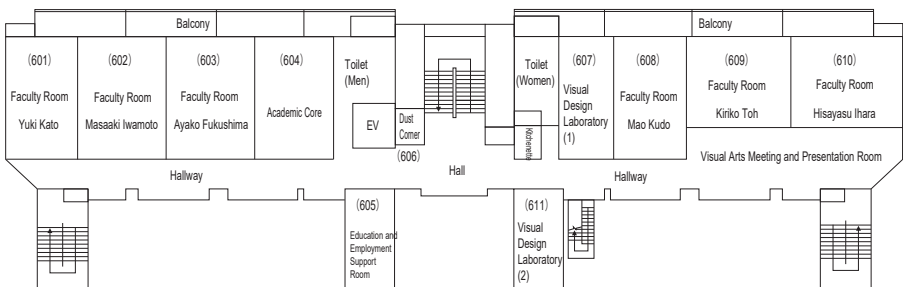

Sixth Floor

Building 3

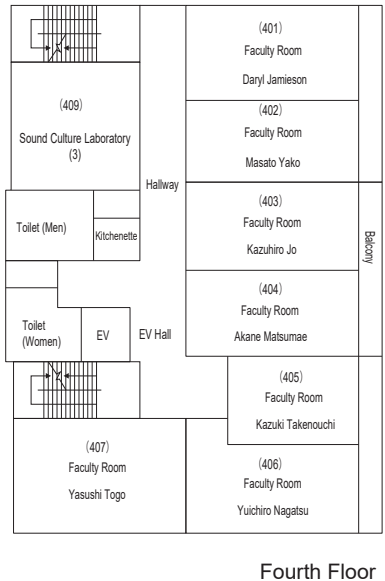
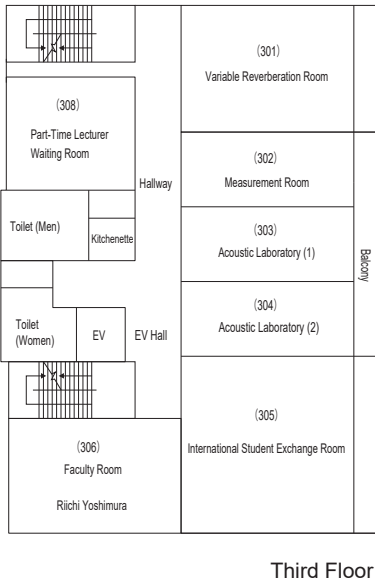
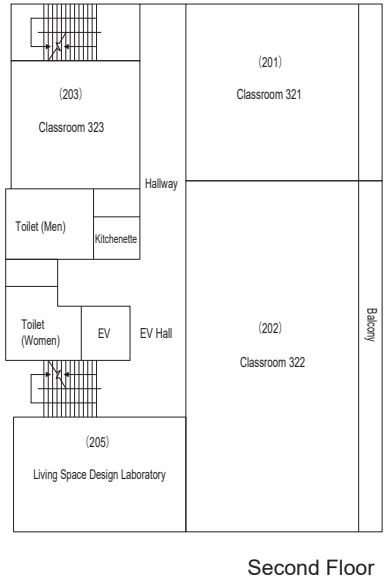
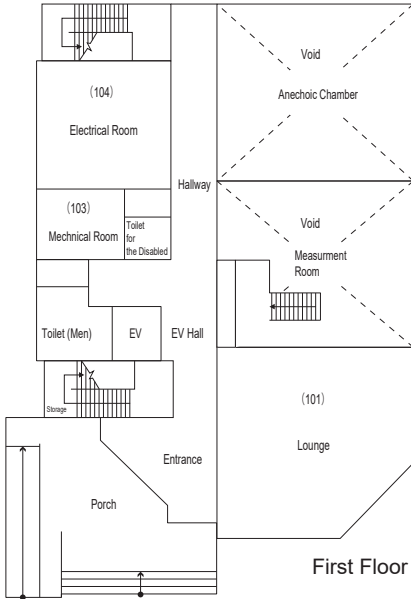

Building 3

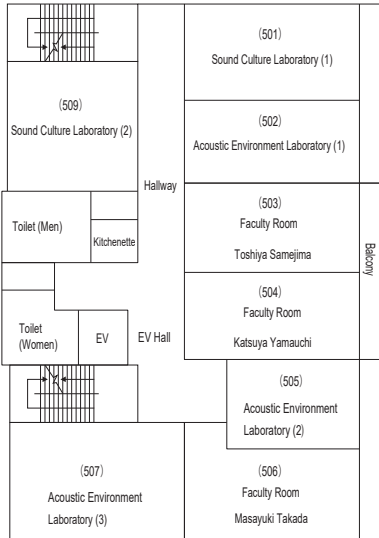

Fifth Floor

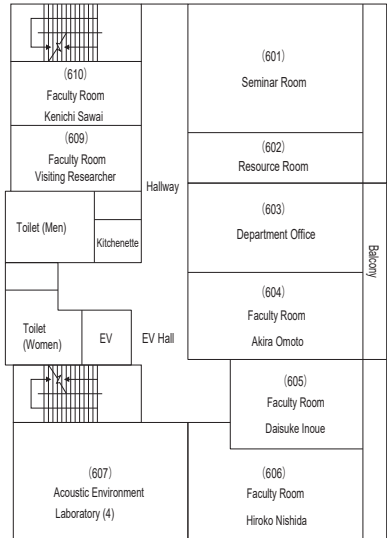

Sixth Floor

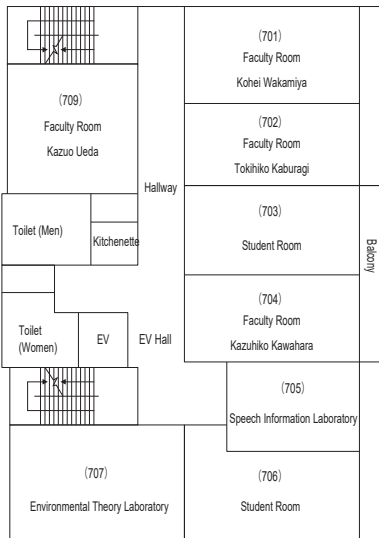

Seventh Floor

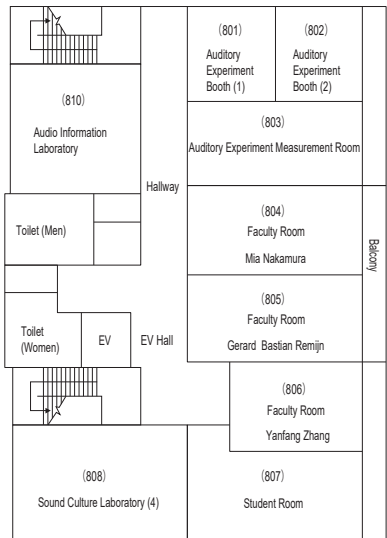

Eighth Floor

Building 4

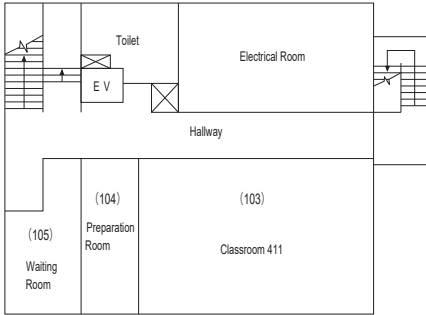

First Floor

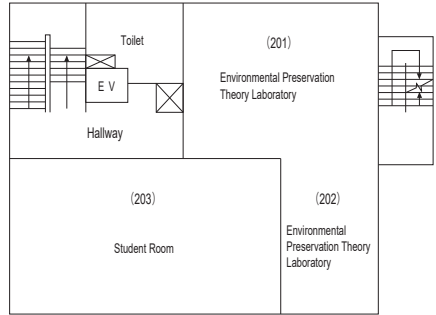

Second Floor

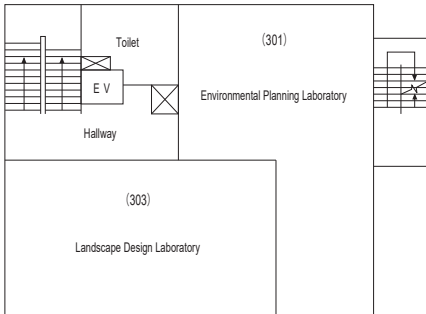

Third Floor

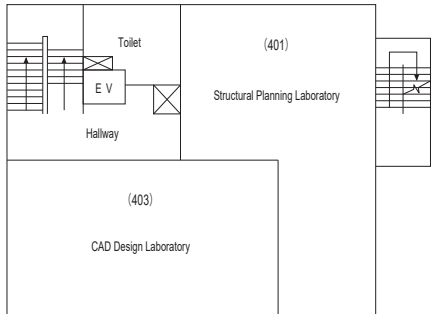

Fourth Floor

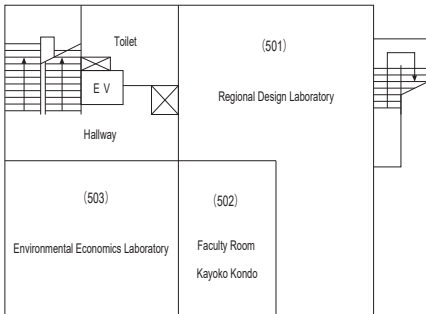

Fifth Floor

Building 5

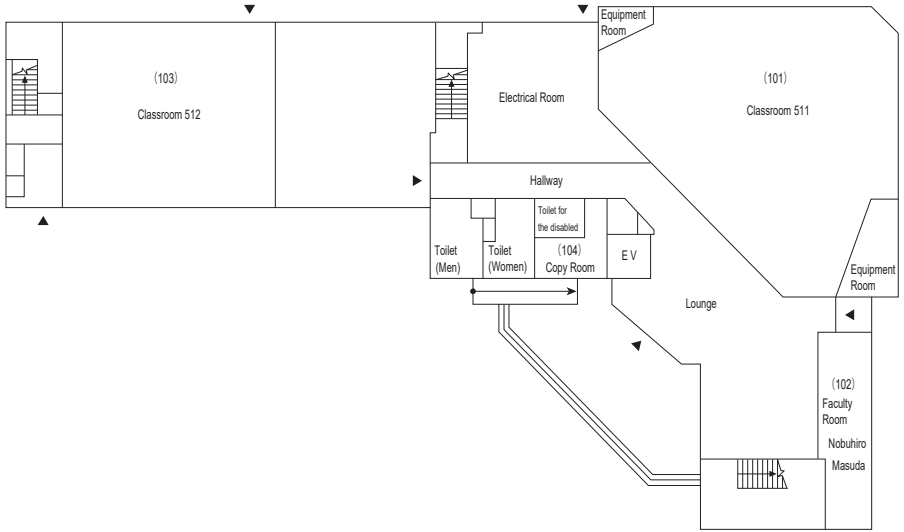

First Floor

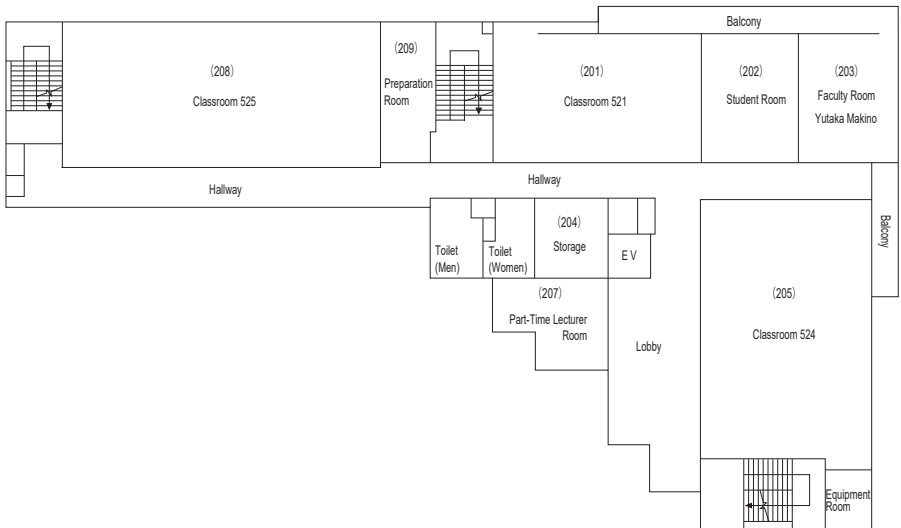

Second Floor

Building 5

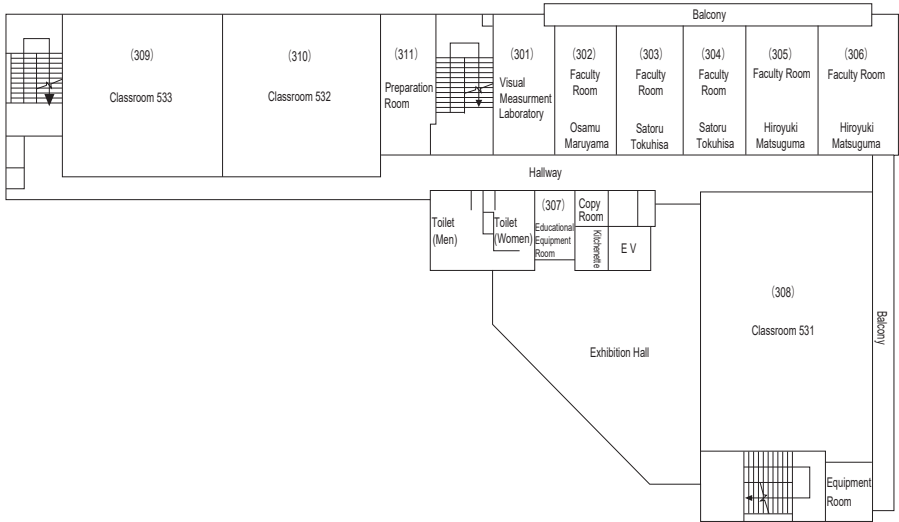

Third Floor

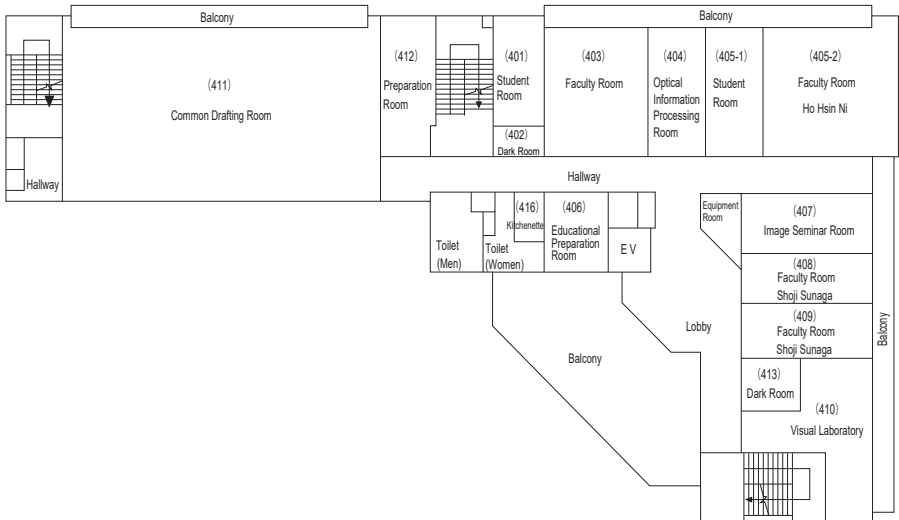

Fourth Floor

Building 5

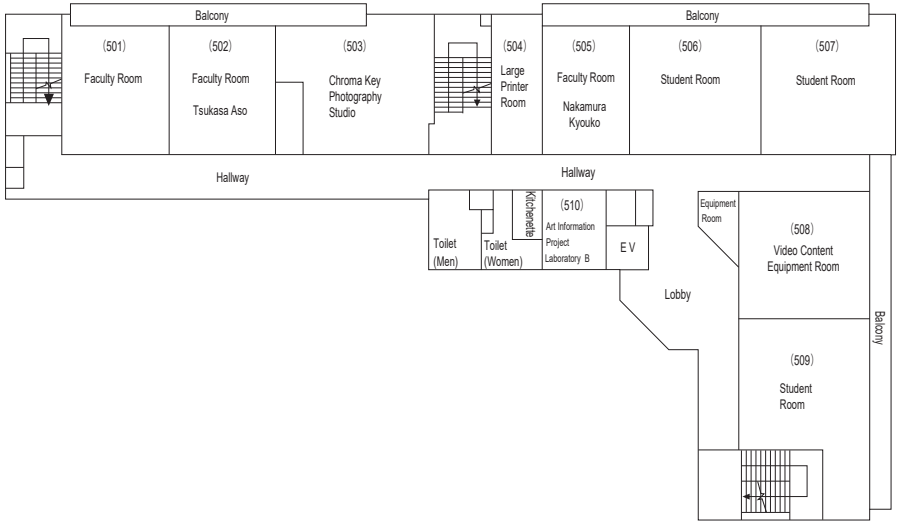

Fifth Floor

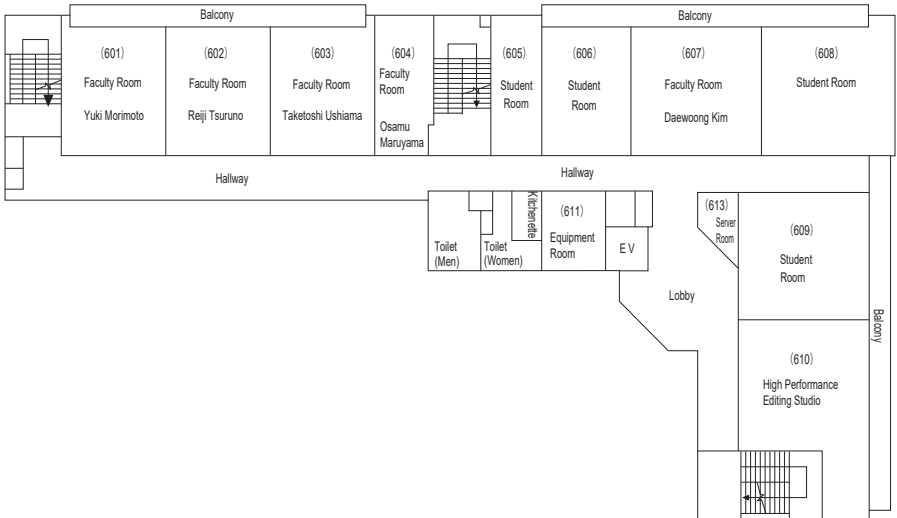

Sixth Floor

Building 5

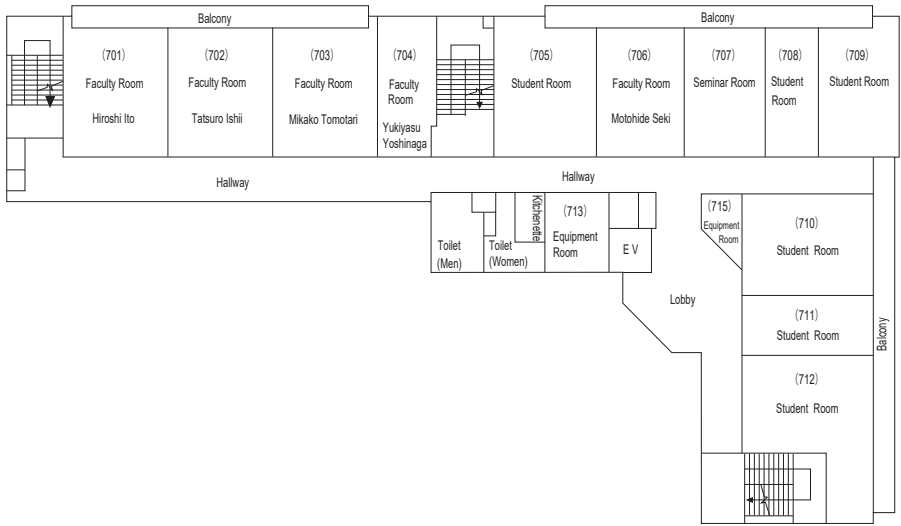

Seventh Floor

Building 6

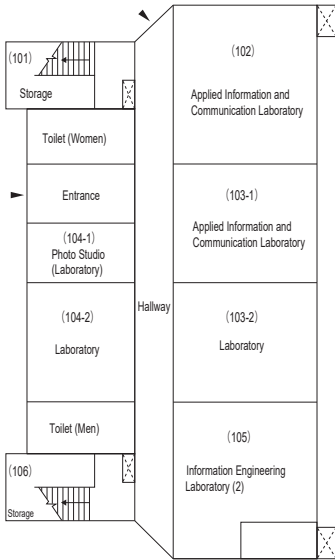

First Floor

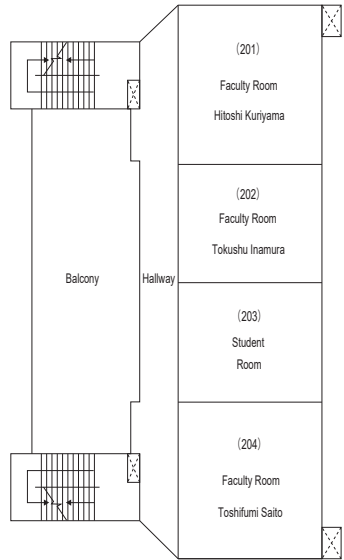

Second Floor

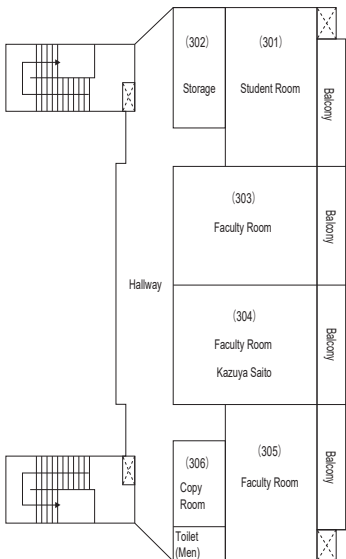

Third Floor

Building 7

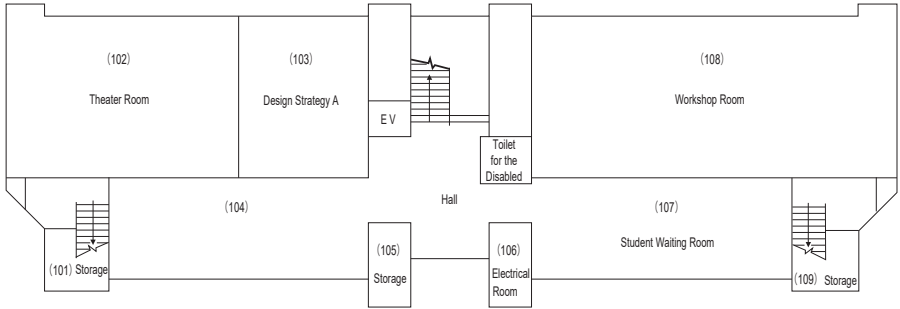

First Floor

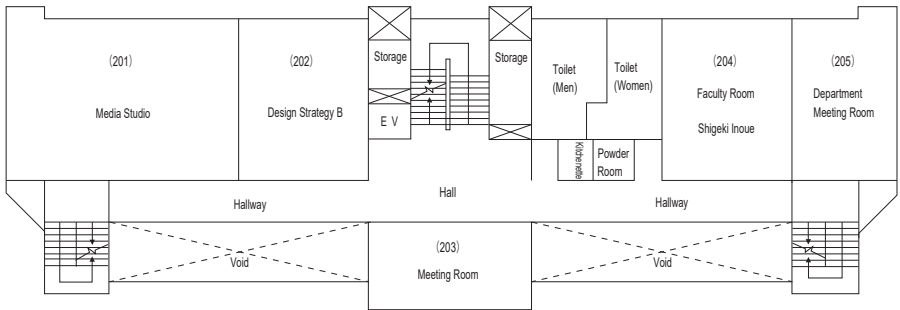

Second Floor

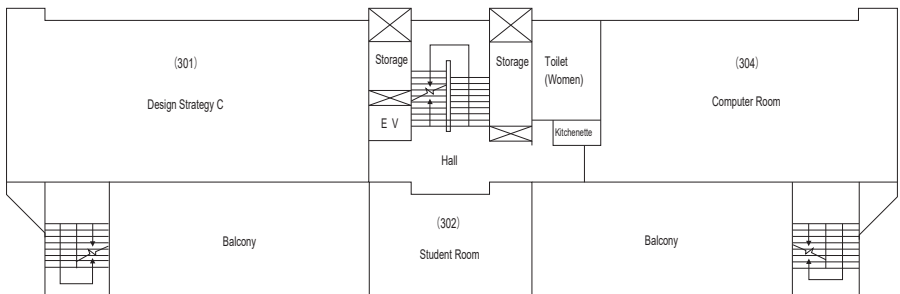

Third Floor

Building 7

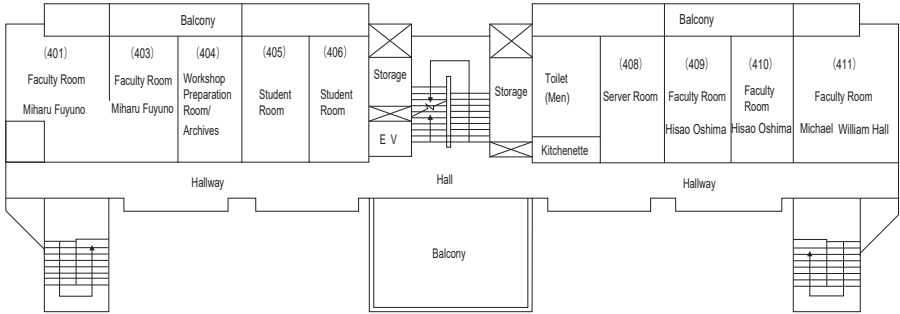

Fourth Floor

Building 8

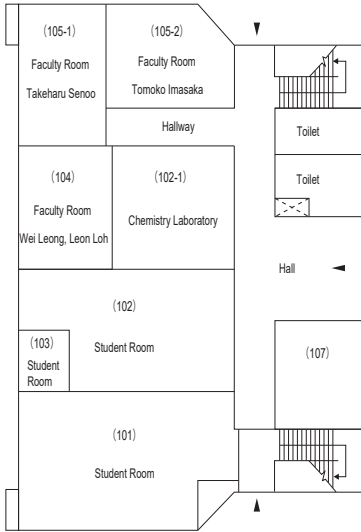

First Floor

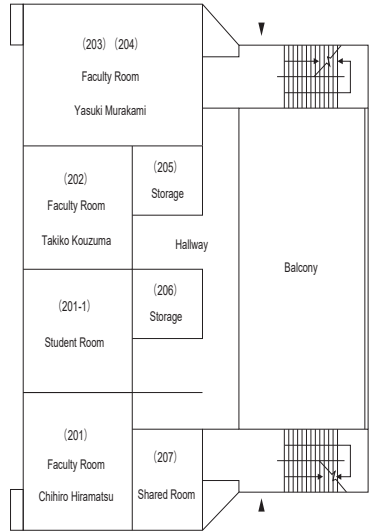

Second Floor

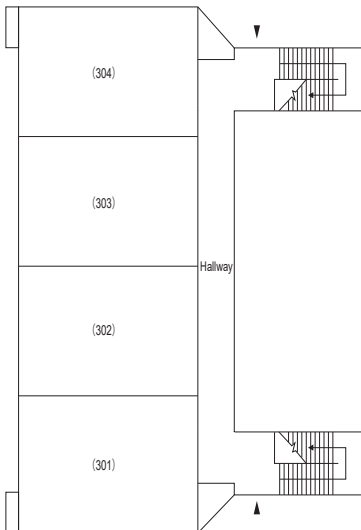

Third Floor

Environmental Research Center

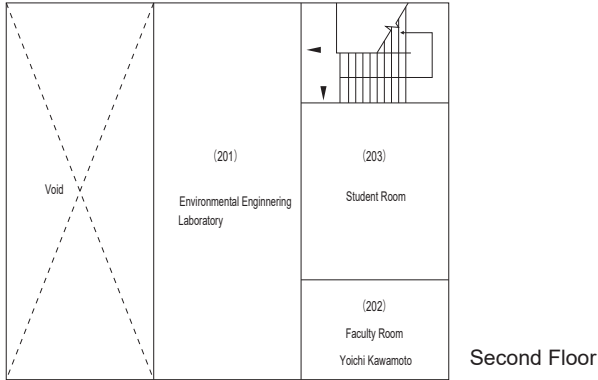
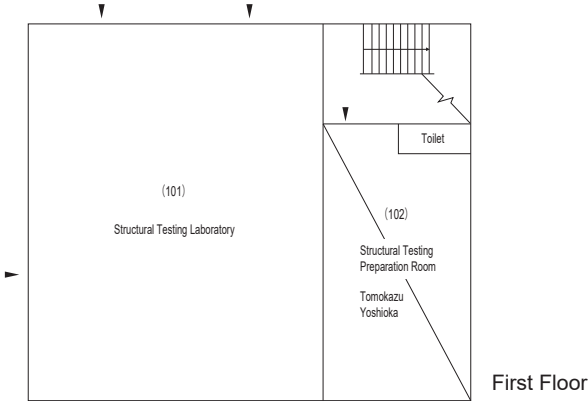

Printing Workshop Second Floor

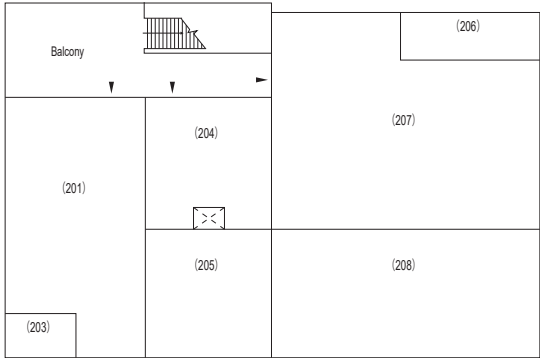

Visual Communication Design Center Second Floor

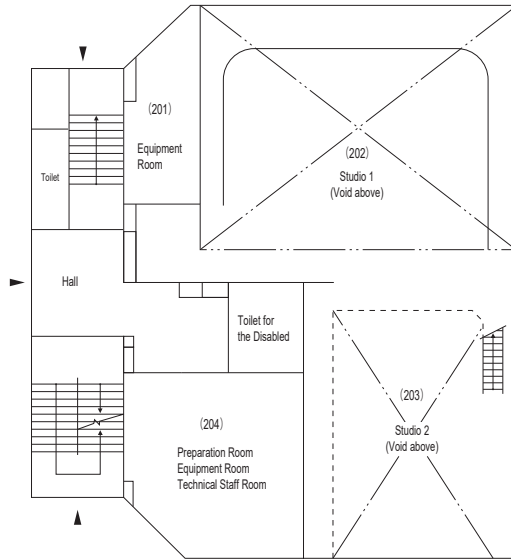

Acoustic Research Center Second Floor

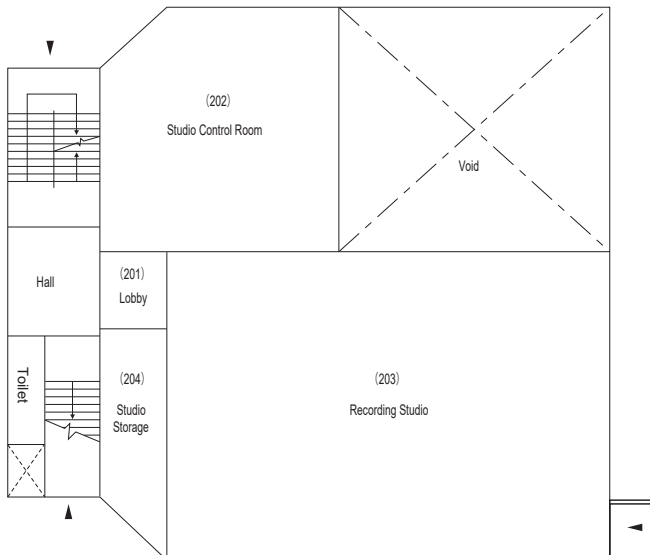

Co-Lab Building

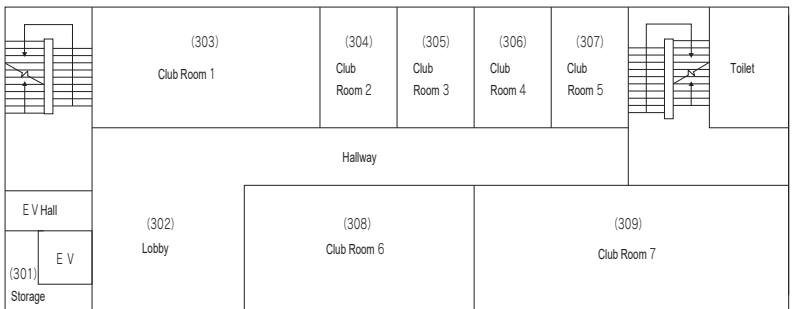
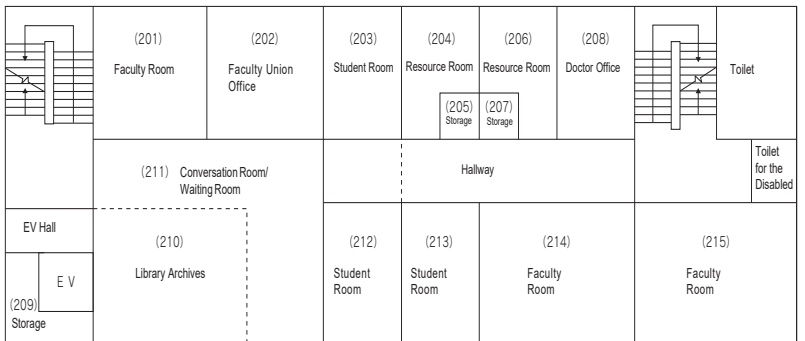
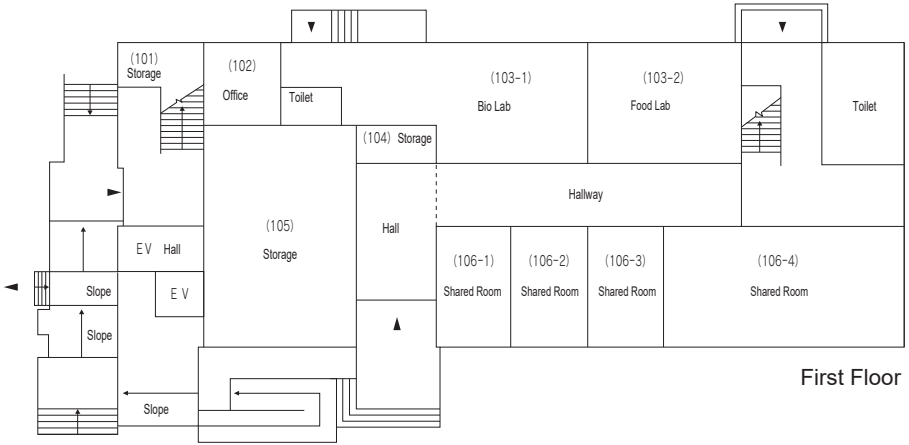

Club Activities Building

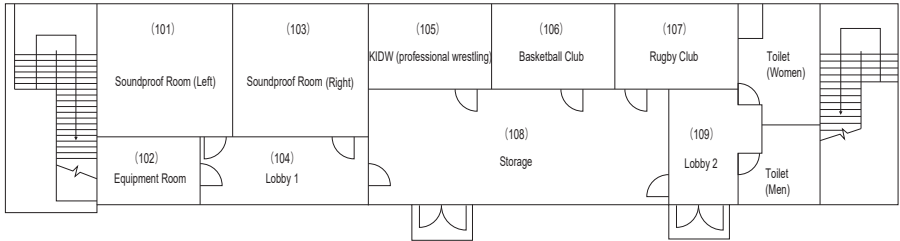

First Floor

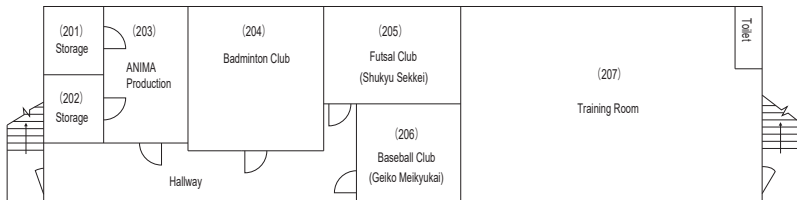

Second Floor

Design Workshop

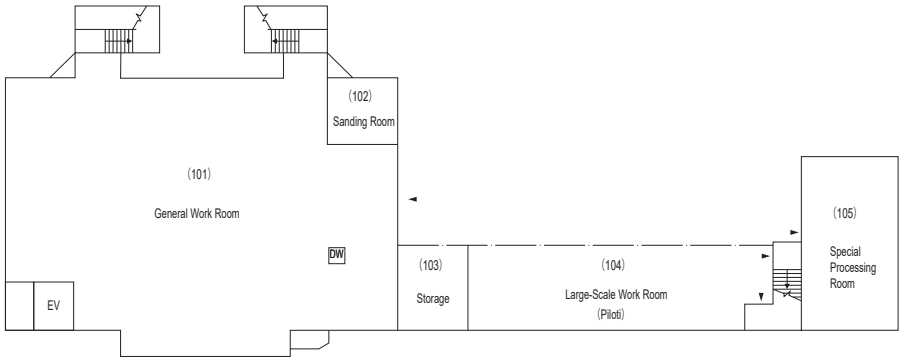

First Floor

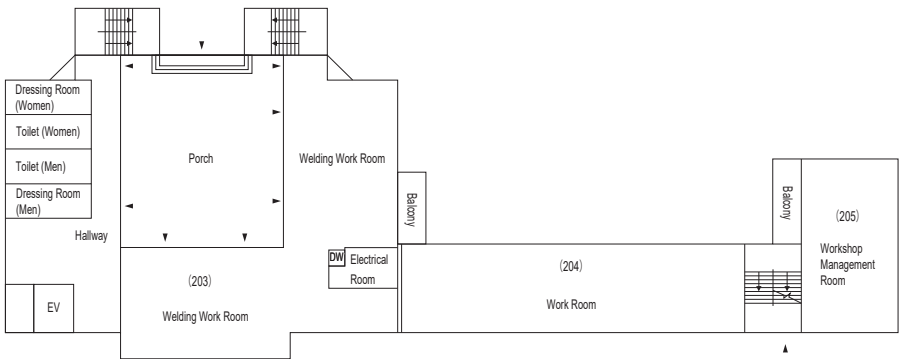

Second Floor

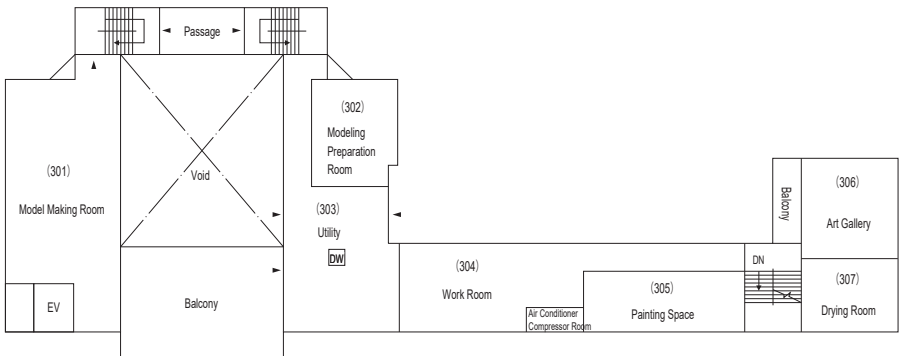

Third Floor

Information Infrastructure Office (Information Infrastructure Initiative Ohashi Office)

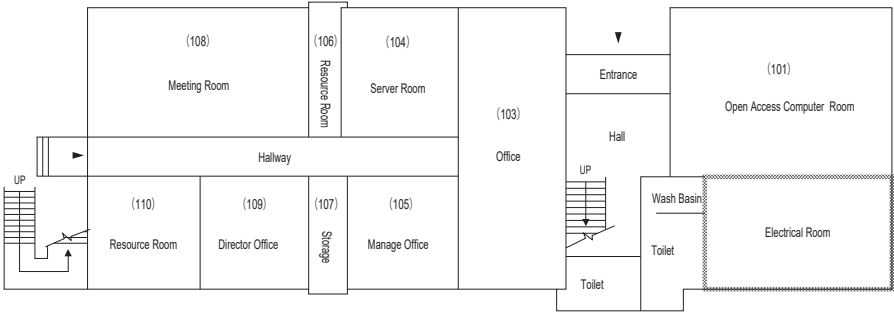

First Floor

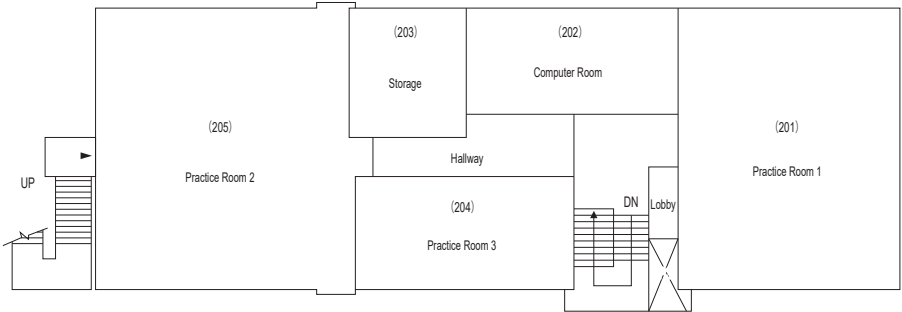

Second Floor

Multi-Purpose Building

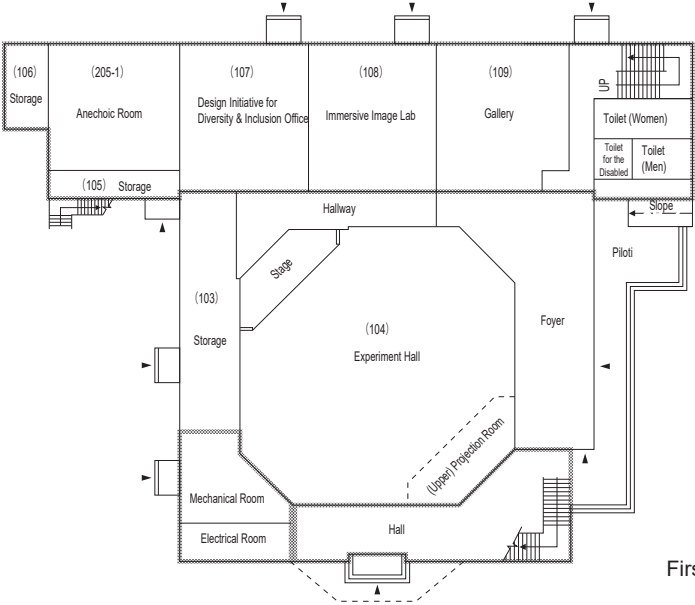

First Floor

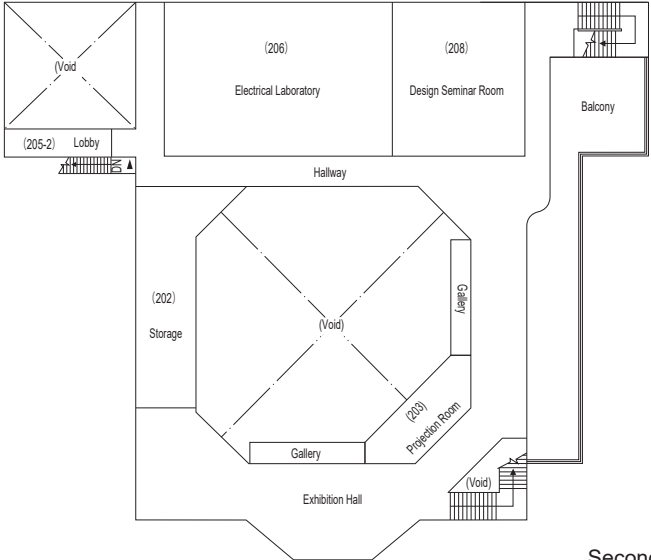

Second Floor

Design Commons

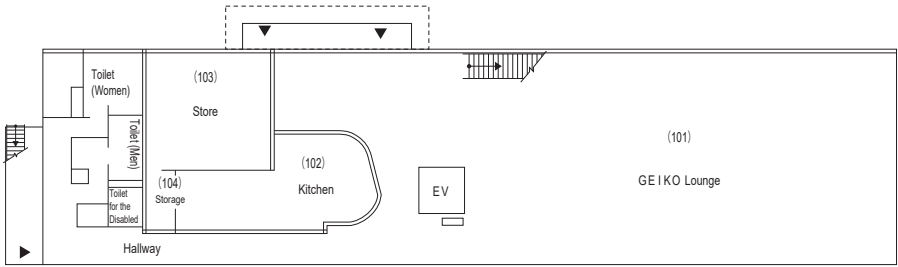

First Floor

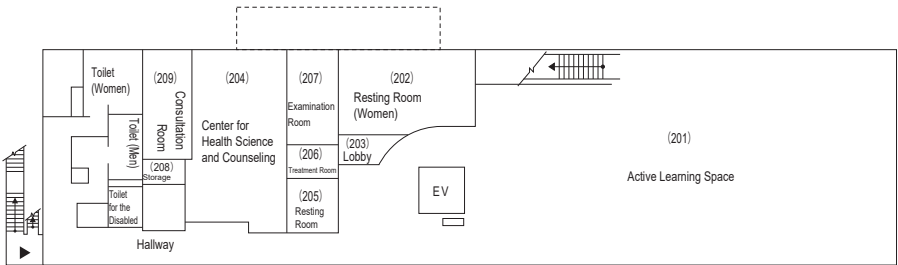

Second Floor

Gymnasium

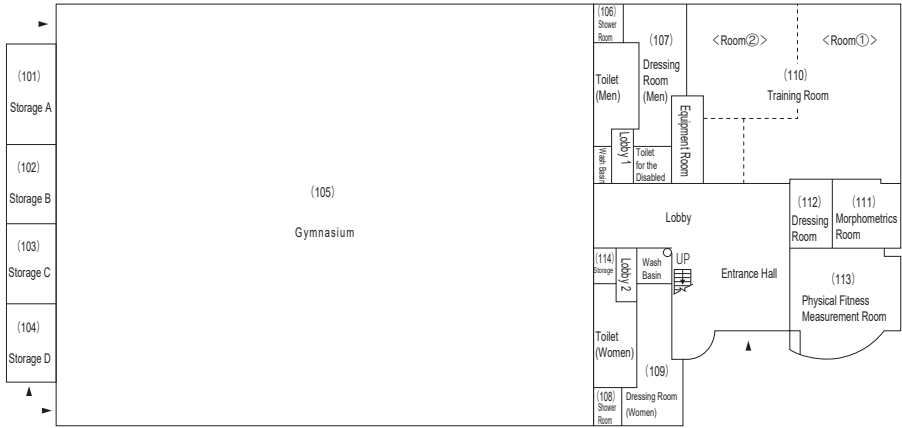

First Floor

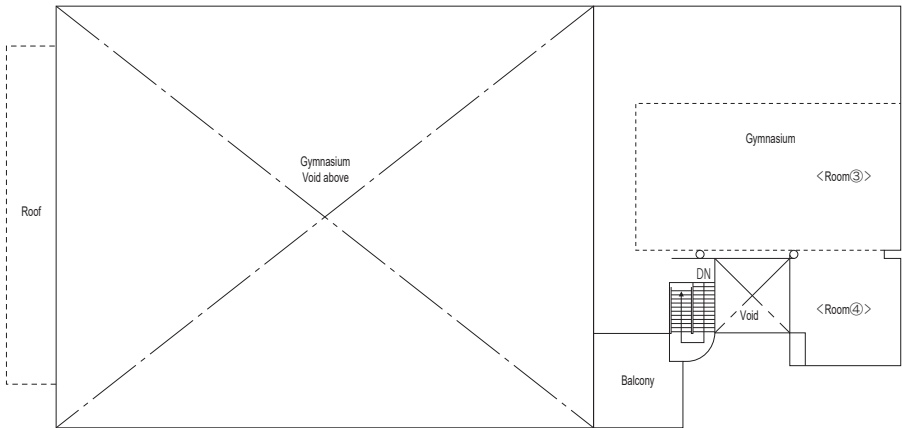

Second Floor

3. Kyushu Institute of Design Student Song



1. はるにははるの おーもいあり、 つど
 2. なつにはなつの おーもいあり、 うれ
 3. あきはあきの おーもいあり、 き
 4. ふゆはふゆの おーもいあり、 きた



い お お き そ れ ぞ れ の、 ゆ
 て ま ゆ き が れ く さ い に、 め
 お お め り お あ れ く い は を、 れ
 る お こ で は あ え れ も ぞ れ に、 ほ
 か こ で は あ え れ も ぞ れ に、 ほ



を 一 わ か て ゆ く す え の、 わ
 ら 一 ち か ら つ た く す え の、 わ
 に 一 い し め つ た く す え の、 わ
 れ 一 お お か れ こ わ が が く の、 こ



ら の あ す を て お ら して む、 2. なつ
 の い の り え む と お す れ ば な む、 3. あ
 わ り え む と お す れ ば な む、 4. ふゆ



ゆ う ち か い 一 を と も に は た す べ し。
 (い を と も に)

10th Anniversary Memorial Collection

Kyushu Institute of Design Student Song (I)

Four Seasons in the Schoolhouse

Lyrics by 返田 良
 Composed by 川畑邦弘

- 1 Spring has its own way of thinking
Gathered together, we share the dreams, and light our way to tomorrow
- 2 Summer has its own way of thinking
While we entrust our dreams to the flickering flames of the school festival, the lives that burn will dance
- 3 Autumn has its own way of thinking
There are things that are sorrowful and conceited, but if we can learn the truth of design here, then...
- 4 Winter has its own way of thinking
Let each of us be honored in our coming a new life, and let our schoolmates fulfill their vows together

注：1. 2. 3. 4番とも括弧内は二部にわかれて
 いるが、1. 2. 3番については下声、4番
 については上声が主旋律になる。しかし
 実際は二部合唱になるのが望ましい。

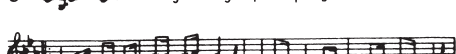

1 かぜよくーちよ ひーかり よ ふきすきべー わがむねに、
 2 のぼるあきひに みんごと あかき夕日に なみだすて

こいよめ ちーかいよ つらぬきどうせー わがおもい、
 ほるからへい たたたん ながれるほし ゆめたくし、

あしたゆくーとおきみち やみにきえて も、
 あしたきつく せいめんの あかしとめて、

きのうまでのはるかゆめ ひかりにかえ て、 とべ
 うたえおのれと そうぞうの ちかいかへ て、 とべ

おおぞらとべ うなばら ちからつづく そのひま で、
 おおぞらとべ うなばら ちからつづく そのひま で、

ゆ こうわがとも わこおど よ、きゆうしゅうげいこーだ い
 ゆ こうわがとも わこおど よ、きゆうしゅうげいこーだ い

10th Anniversary Memorial Collection

Kyushu Institute of Design Student Song (II)

Kyushu Institute of Design Youth Cheering Song

Lyrics and Composed by 三木弘和

- 1 The wind, the clouds, the light, blowing wildly in my heart
Love, dreams, vows, penetrate my thoughts
The distant road to tomorrow, though it fades into darkness
Yesterday's faraway dream, turn it into light
Let's fly to the sky, let's fly to the sea, let's go to the day when our strength continues
Let's go, my friends, young people, Kyushu Institute of Design
- 2 As the sun rises, I argue with myself, and as the red sun sets, I weep
Let's set off on a journey to the distant horizon, trusting our dreams to the flowing stars
Seeking the light of youth to build tomorrow
Sing to the vow of self and creation
Soar through the skies, soar through the seas, until the day our strength endures
Let's go, my friends, young people, Kyushu Institute of Design

Looking Toward Tomorrow

Lyrics and Composed by 都甲 康至

C
 がい た そらを みつめても 一なに
 F G7
 も うまれ ない、 ー うつろ
 Em/B Am
 な ときになが-さされても 一なに
 F G7 C
 ちー うま-れな い きぼう
 F G C G7
 のかわに かける にじの はし-のよう-にあた
 F G C G7
 らしいせかいをー ゆめ-みて-あゆ
 Am Am/G F G7
 み つづけようー こ のみちを-みん
 F G7 C
 な のこころを あわせ て。 おもい
 C Em/B Am
 でに すがり つい-てー も 一なに
 F G7
 も まれ ない、 ー どく
 C Em/B Am
 な こころを しん-じても 一なに
 F G7 C C7
 もー うま-れな い どんな
 F G C G7
 ちいさな こどに でーもーあ
 F G C G7
 いを かけて あげー ら-れる-ひと
 Am Am/G F G7
 のこころをー た いせつにして-みん
 F G7 C
 な の-あいを あわせ て ひと
 Am Am/G F G7
 のこころをー た いせつにして-みん
 F G7 C fm C7
 な のあいを あわせ てー

1 Even though stare at the dry sky
 Nothing will come of it
 Even though swept away in a maze
 Nothing will come of it
 Over the river of hope
 Like a rainbow bridge
 Dreaming of a new world
 Let's keep walking
 On this path
 With everyone's heart united

2 Even though hang on to my memories
 Nothing will come of it
 Even though trust in a lonely heart
 Nothing will come of it
 No matter how small it may seem
 I can give my love to it
 Cherish the hearts of others
 With everyone's love together
 Cherish the hearts of others
 With everyone's love together



われらわら 1.とも-そうじやない かわか
2.もや-そうじやない かまほ
3.きす-こうじやない かかが



き-せいしゆん-きほうの-ひ-かざり-あるわか
ゆいじおねつ-そのほ-のお-たか-ふるせい
やくみらい-えいえん-の-こころ-をひらい



い-じ-か-ん-を-お-か-し-て-つ-ぎ-な-る-じ-だ-い
しん-よ-に-し-め-が-き-ん-と-か-が-や-く-ひ-と-み
て-ふ-る-き-を-み-つ-め-ま-こ-と-を-ち-と-め



を-む-か-え-る-た-め-に-い-ざ-と-ち-き-
は-に-が-ま-ち-て-ら-す-い-ざ-も-や-き-
て-あ-ら-た-を-つ-く-り-い-ざ-き-す-か



ん-ほ-う-の-ひ-と-も-せ-と-も-せ-と-も
ん-じ-お-つ-の-ほ-の-お-も-や-せ-も-や-せ-も-や
ん-わ-れ-ら-の-み-ら-い-き-ず-き-ず-け-き-ず

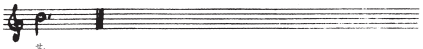

せ-
せ-
け-

20th Anniversary Memorial Collection

Kyushu Institute of Design Student Song (IV)

————— Come on, Young people !! —————

Lyrics and Composed by 永沢裕之

- 1 Let's light it, young people
Young youth, Light of hope
to enjoy our limited youthful time and
welcome the next era
Let's light, Light of hope!
Light it, light it, light it !!
- 2 Let's burn it down, young people
Dazzling passion, the flame
To show the world the rising spirit
The shining eyes light up the world of pain
Let's burn the flame of passion
Burn it, burn it, burn it !!
- 3 Let's build it, young people
A bright future, eternal
Open our hearts and look at the old,
In serach of truth and create the new
Let's build our future
Build it, build it, build it !!

Rut to Tomorrow

Lyrics by 植田洋一

Composed by 岡崎道成

1. な が る と き が ー は や か ら う と お そ か ら う と
 2. な が る と き が ー は や か ら う と お そ か ら う と

いまはここにたつとつめりあふたなかまたら
 いつの日にゆめをたなきあまるともな

じぶんの夢めをーおいかけることらできず
 きみのなをたなみたはきつとかなるまで

きみがいないならだれかにしゃべって
 こころのなかでみちしるべになるみうしなう

こころよーはるかなつへと
 こころないあきらかなつへと

きせつがめぐるようにきみがあるさすのを
 きせつがめぐるようにきみのすてきな笑顔

みんながまっつてるこころがはるくな
 みんながまっつてるげんきほじぶんだけ

ったならあるさすほいいからつかれたときほほ
 きなれどちもがそばにいるつまずきあすをほ

んがなかつたまればーいいから
 じることほしくなくてーいいからー

- 1 No matter how fast or slow the flow
 Now we are here as one
 The friends I've met
 My dream
 If you can't chase your dreams and you're crying
 Tell someone
 As the seasons turn from spring to summer
 Everyone is waiting for you to start walking
 If you feel lighter
 Just start walking
 If you feel tired
 Don't hesitate to stop
- 2 No matter how fast or slow the flow
 Let's be friends who encourage each other any day
 The tears you shed take on a new shape and guide you in your
 mind
 You never lose sight of it.
 As the seasons change from autumn to winter
 Everyone is waiting for your beautiful smile
 You have to find your own energy
 Your friends are there for you
 There's no need to be ashamed of your failure and wound